

### DESCRIPTION

The Eclipse 705 Transmitter is a loop-powered, 24 V DC liquid-level transmitter based on the revolutionary Guided Wave Radar (GWR) technology. Encompassing a number of significant engineering accomplishments, this leading edge level transmitter is designed to provide measurement performance well beyond that of many traditional technologies, as well as “through-air” radars.

The innovative enclosure is a first in the industry, orienting dual compartments (wiring and electronics) in the same plane, and angled to maximize ease of wiring, configuration, set-up and data display.

This single transmitter can be used with all probe types and offers enhanced reliability, for use in SIL 2 loops as 1oo1.

### FEATURES

- \* “REAL LEVEL”, measurement not affected by media variables eg. dielectrics, pressure, density, pH, viscosity, ...
- \* Easy bench configuration - no need for level simulation.
- \* Two-wire, intrinsically safe loop powered level transmitter.
- \* 20-point custom strapping table for volumetric output.
- \* 360° rotatable housing can be dismantled without depressurizing the vessel via “Quick connect/disconnect” probe coupling.
- \* Two-line, 8-character LCD and 3-button keypad.
- \* Probe designs: up to +430 °C / 430 bar (+800 °F / 6250 psi).
- \* Saturated steam applications up to 155 bar @ +345 °C (2250 psi @ +650 °F).
- \* Cryogenic applications down to -196 °C (-320 °F).
- \* Integral or remote electronics.
- \* Suited for SIL 1 or SIL 2 Loops (full FMEDA report available).



### APPLICATIONS

**MEDIA:** Liquids or slurries; hydrocarbons to water-based media (dielectric 1,4 - 100) and solids (dielectric 1,9 - 100).

**VESSELS:** Most process or storage vessels up to rated probe temperature and pressure.

**CONDITIONS:** All level measurement and control applications including process conditions exhibiting visible vapors, foam, surface agitation, bubbling or boiling, high fill/empty rates, low level and varying dielectric media or specific gravity.

Ask for your free copy of the Eclipse® 705 performance report by WIB/Evaluation International (SIREP)/EXERA.

### Measures real «LEVEL, VOLUME, INTERFACE»

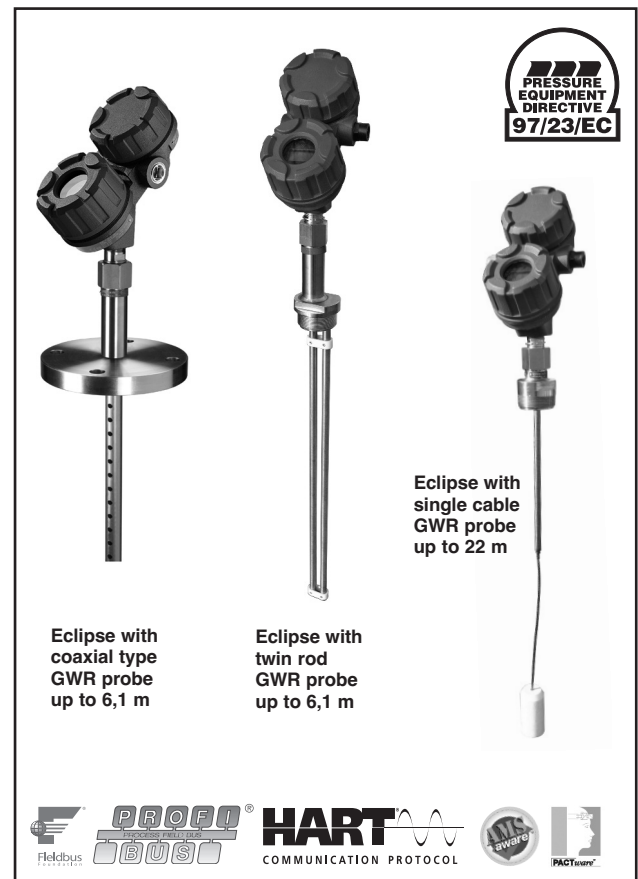

### AGENCY APPROVALS

Agency	Approvals
ATEX Ex	II 3 (1) G EEx nA [ia] IIC T6, non sparking <sup>①</sup> II 3 (1) G EEx nA [nL] [ia] IIC T6, FNICO – non incendive <sup>①②</sup> II 1 G EEx ia IIC T4, intrinsically safe II 1 G EEx ia IIC T4, FISCO – intrinsically safe <sup>②</sup> II 1 / 2 G D EEx d[ia] IIC T6, explosion proof
Lloyds	Primary level safety device for steamdrums conform to - EN 12952-11 (water tube boilers) - EN 12953-9 (shell boilers)
TÜV	WHG § 19, overfill prevention
AIB	VLAREM II – 5.17.7
FM/CSA <sup>②</sup>	Non Incendive / Intrinsically safe / Explosion proof
LRS	Lloyds Register of Shipping (marine applications)
RosTech/FSTS GOST-K/GGTN-K	Russian Authorisation Standards

<sup>①</sup> Probe is intrinsically safe to ATEX II 1 G EEx ia IIC T6 and can be used in zone 0, on flammable liquids.

<sup>②</sup> Foundation Fieldbus™ and Profibus PA units are FNICO (non sparking), FISCO (intrinsically safe) and ATEX – FM/CSA explosion proof approved.

# TECHNOLOGY

## Level

Eclipse® Guided Wave Radar is based upon the technology of TDR (Time Domain Reflectometry). TDR utilizes pulses of electromagnetic energy transmitted down a wave guide (probe). When a pulse reaches a liquid surface that has a higher dielectric constant than the air ( $\epsilon_r$  of 1) in which it is traveling, the pulse is reflected. The travelling time of the pulse is measured via ultra speed timing circuitry that provides an accurate measure of the liquid level. Even after the pulse is reflected from the upper surface, some of the energy continues down the GWR probe through the upper liquid. The pulse is again reflected when it reaches the higher dielectric lower liquid, as shown in the illustration.

## Interface

The Eclipse® 705, is capable of measuring both an upper liquid level and an interface liquid level. It is required that the upper liquid has a dielectric constant between 1.4 and 5, and the lower liquid has a dielectric constant greater than 15. A typical application would be oil over water, with the upper layer of oil being non-conductive ( $\epsilon_r \pm 2,0$ ), and the lower layer of water being very conductive ( $\epsilon_r \pm 80$ ). The thickness of the upper layer must be  $> 50$  mm (2"). The maximum upper layer is limited to the length of the 7MT GWR probe, which is available in lengths up to 6,1 m (240").

## Liquid level

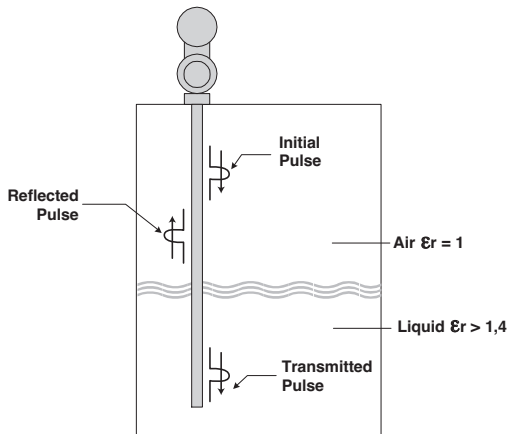

## Emulsion layers

As emulsion layers can decrease the strength of the reflected signal, the Eclipse® 705 should only be utilized in those interface applications that have clean, distinct layers. Contact the factory for application assistance.

## Interface

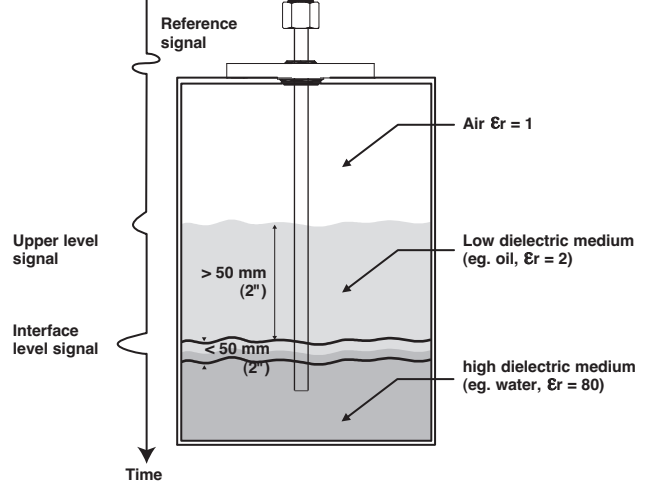

## Solid level

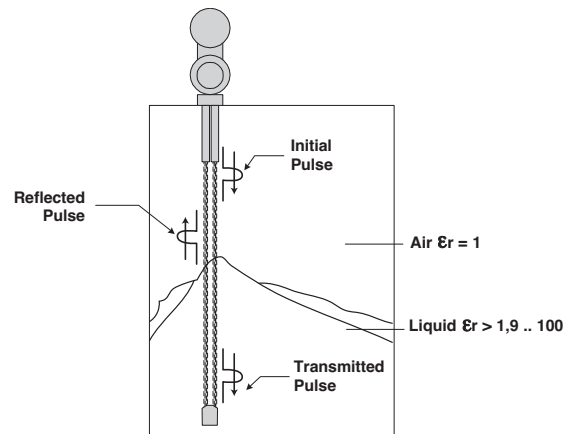

# PACTware™ PC SOFTWARE PROGRAM

FDT technology provides an open communication interface between field instruments of various communication protocols and the host/ DCS system. The DTM driver is typical for one type of instrument and delivers the full functionality of the device added with graphical user interface via a laptop or PC. Magnetrol transmitters use the free shareware PACTware™ software to support DTM drivers and the FDT functionality. Via PACTware™ it becomes easy to configure, monitor and diagnose a Magnetrol transmitter from distance or even to call for factory assistance over the internet via the supply of screenshots of echo curves and trending graphs. Magnetrol DTM library HART® has passed the dtmINSPECTOR, the official FDT interoperability test and certification tool. The Magnetrol DTM's are free of charge and can be downloaded from [www.magnetrol.com/products/software/PACTware™](http://www.magnetrol.com/products/software/PACTware™) or obtained via CD Rom from your nearest Magnetrol contact.



# REPLACEMENT OF DISPLACER TRANSMITTER

Eclipse® has proven to be the perfect replacement for existing torque tube transmitters. In hundreds of applications around the globe, customers have found Eclipse® Guided Wave Radar superior to torque tube transmitters:

- **Cost:**  
A new Eclipse® costs only slightly more than rebuilding an aging torque tube.
- **Installation:**  
No field calibration is necessary; it can be configured in minutes with no level movement. Pre-configuration from factory is free of charge.
- **Performance:**  
Eclipse® is not affected by changes in specific gravity or dielectric.
- **Ease of replacement:**  
Proprietary flanges are offered so existing chamber/ cages can be used.

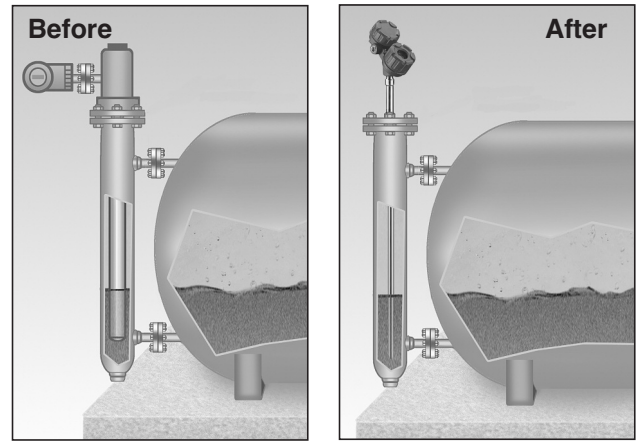

In order to match the proper Eclipse transmitter with the proper external cage, consider the following:

- **Type of application** – use the applicable GWR probe, see page 5.
- **Overflow proof:** Overflowing occurs when the level rises above the max level – radar based equipment may provide erroneous output in this zone unless an adapted design is used. GWR probes without top transition zone (e.g. 7MR, 7MD, 7MT) are always safe to use – only in cases where the application demands for a different probe type, other selections should be considered and the recommended precautions followed.
- **Min cage size:**
  - coaxial type: min 2"/DN 50
  - twin rod type: min 3"/DN 80
  - single rod type: consult factory.

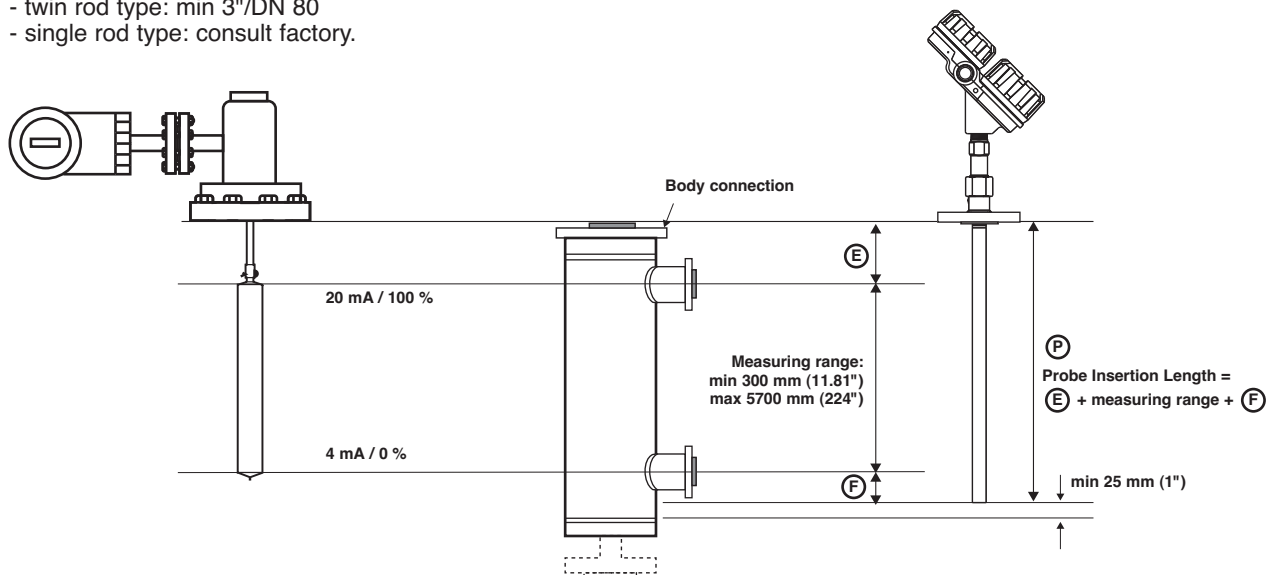

## Indicative probe length for replacing displacer transmitters

Below table helps to define the GWR probe length based upon the length of the most common displacer transmitters. Consult the selection guide on the next page.

Manufacturer	Type	Process connection	Displacer length inches (mm)	Probe length <sup>①</sup> mm (inches)
Magnetrol®	EZ & PN Modulevel®	ANSI/DIN flange	≥ 14" (356)	Displacer + 178 (7)
Masoneilan®	Series 1200	Proprietary flange	≥ 14" (356)	Displacer + 203 (8)
		ANSI/DIN flange	≥ 16" (406)	Displacer + 203 (8)
Fisher® series 2300 & 2500	249B, 259B, 249C cages	Proprietary flange	≥ 14" (356)	Displacer + 254 (10)
	other cages	ANSI flange	≥ 14" (356)	consult factory
Eckhardt®	Series 134,144	ANSI/DIN flange	≥ 14" (356)	consult factory
Tokyo Keiso®	FST-3000	ANSI/DIN flange	H = 11.8" (300)	Displacer + 229 (9)
		ANSI/DIN flange	≥ H = 19.7" (500)	Displacer + 229 (9)

<sup>①</sup> Round down resulting calculation to the nearest cm.

# PROPRIETARY FLANGES

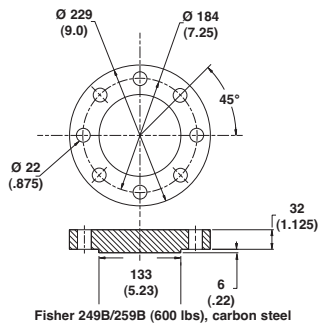

Figure 1

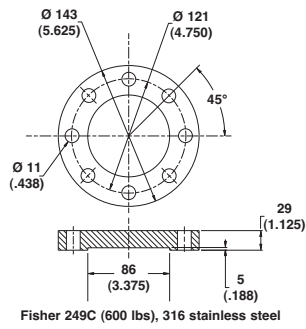

Figure 2

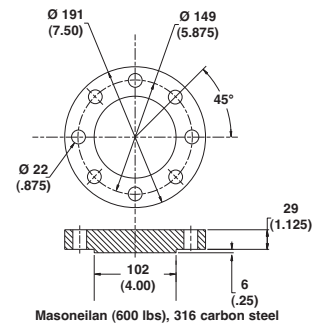

Figure 3

## CAGES

Eclipse can be built into cages as small as DN 50 / 2". When a new cage is needed, it can be ordered together with the Eclipse. Magnetrol has a long tradition in offering cost effective cages. Magnetrol cages comply with PED regulations and are available with a wide variety of options.

Measuring span	30-610 cm (12-240") ①
Materials of construction	Carbon steel or 316 (1.4401) stainless steel
Process connection sizes	¾", 1", 1 ½", 2"
Process connection ratings	150#-2500# ANSI
Configurations	Side-Side and Side-Bottom
Process pressures	Up to 430 bar (6250 psig) ①
Process temperatures	Up to +430 °C (+800 °F) ①

① Limitations are defined per selected GWR probe.



For more details – consult bulletin 57-140.

## REPLACEMENT OF TOP/BOTTOM CAGES

In addition to Magnetrol's Torque Tube Cage Flange options, the Eclipse® 705 transmitter and 7EK GWR probe/cage can also be used in replacing existing Top/Bottom and Top/Side torque tube installations. After removal of the existing torque tube cage assembly (controller, displacer and cage), Eclipse Guided Wave Radar may then be installed directly in its place. Several models are available for some of the major torque tube displacer transmitter manufacturers. Because the Model 7EK probe/cage mounting dimensions and measuring ranges match the original manufacturer's specification, no re-piping is necessary.

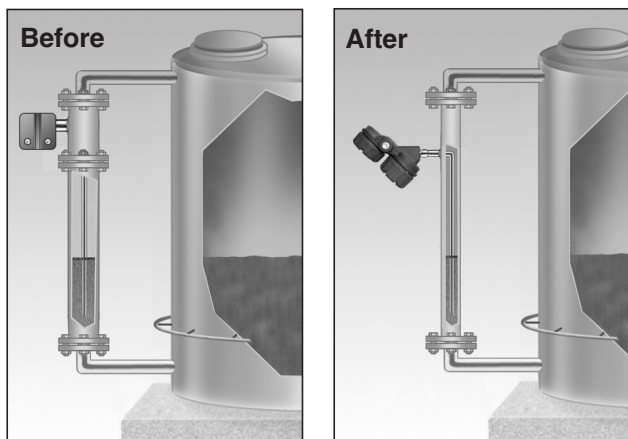

## AURORA™

Aurora® is the innovative combination of the Eclipse® Guided Wave Radar and a Magnetic Level Indicator (MLI). The MLI indicator rail offers the Eclipse a highly visible level indication that may obsolete the need for local indicators. The integration of these two independent technologies provides an excellent redundancy in one integrated design. With Aurora® it is even possible to plan maintenance ahead. Maintenance becomes needed when build up in an installation has surpassed the allowable limit. Build up on the float inside the MLI cage will force it to sink deeper in the liquid while the measurement of the Eclipse will not see any build up until its both lead elements are completely clogged. In this way, the float will indicate a lower level versus the real level measured by the Eclipse. The degree of deviation between both read outs is a worthwhile tool to determine the real need for maintenance.



For more details – consult bulletin 57-138.

## HYGIENIC ECLIPSE 705

Eclipse 705 is available with a deep drawn housing and a 0,4 µm (RA 15) finished single rod GWR probe for use in ultra clean environments.

For more details – consult bulletin 57-110



# SELECTION GUIDE

## COAXIAL TYPE GWR PROBE



signal propagation

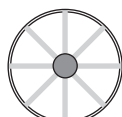

end view

## TWIN ROD/CABLE TYPE GWR PROBE



signal propagation



end view

## SINGLE ROD/CABLE TYPE



signal propagation

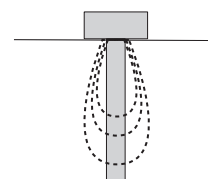

Application	Dielectric limit	Temperature limits	Pressure	Applications			GWR Probe
				Vacuum ①	Overfill safe	Foam ②	

### COAXIAL TYPE GWR probes - max viscosity 500 cP (I.D. 3/4") – 2000 cP (I.D. 1 3/4"). Consult bulletin 57-102

Level	$\epsilon_r$ 1,4 - 100	-40 °C up to +200 °C	max 70 bar	Yes	Yes	No	7MR/7MM
High temp / High pressure Interface	$\epsilon_r$ 1,4 - 100 <sup>③</sup>	-196 °C up to +430 °C	max 430 bar	Full	Yes	No	7MD/7ML
Saturated steam	$\epsilon_r$ 10 - 100	up to +345 °C	max 155 bar	Yes	No	No	7MS
Level / Interface	$\epsilon_r$ 1,4 - 100	-40 °C up to +200 °C	max 70 bar	Yes	Yes	No	7MT/7MN

### Twin rod/cable GWR probes - max 1500 cP

Liquids - rod	$\epsilon_r$ 1,9 - 100	-40 °C up to +200 °C	max 50 bar	Yes	No	Yes	7MB
Liquids: level / interface - cable	$\epsilon_r$ 1,9 - 100	-40 °C up to +200 °C	max 50 bar	Yes	No	No	7M7
Solids - cable	$\epsilon_r$ 1,9 - 100	Ambient	Atmospheric	Yes	No	NA	7M5

### Single rod/cable GWR probes - max 10.000 cP

Liquids - rod	$\epsilon_r$ 1,9 - 100 <sup>④</sup>	-40 °C up to +150 °C	max 70 bar	Yes	No	Yes	7MF
Liquids - cable	$\epsilon_r$ 1,9 - 100 <sup>④</sup>	-40 °C up to +150 °C	max 70 bar	Yes	No	Yes	7M1
Solids - cable	$\epsilon_r$ 4 - 100	Ambient	Atmospheric	Yes	No	NA	7M2
High temp / high pressure	$\epsilon_r$ 1,9 - 100 <sup>④</sup>	-40 °C up to +315 °C	max 207 bar	Yes	No	Yes	7MJ

① Each Eclipse probe can be used for vacuum service (negative pressure) but only the Borosilicate GWR probes (7MD/7ML) are suited for full vacuum conditions (Helium leak < 10<sup>-9</sup> cc/s @ 1 bar abs.)

② Eclipse is ideally suited to be used on foaming applications but in specific conditions where dense foam can enter/hydrate in the stilling well, coaxial GWR probes are not recommended.

③ Depending spacer material. See model selection 7MD/7ML GWR probe.

④ For media with  $\epsilon_r$  1,9 up to 10, GWR probe must be mounted in between 75 mm and 150 mm (3"-6") away from the metal tank wall or in a metal cage / stillwell.

## DIMENSIONS in mm (inches)

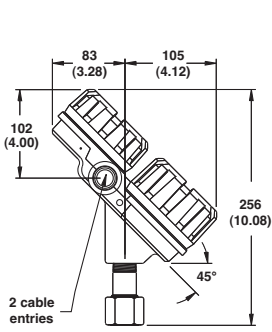

**Integral Electronics**

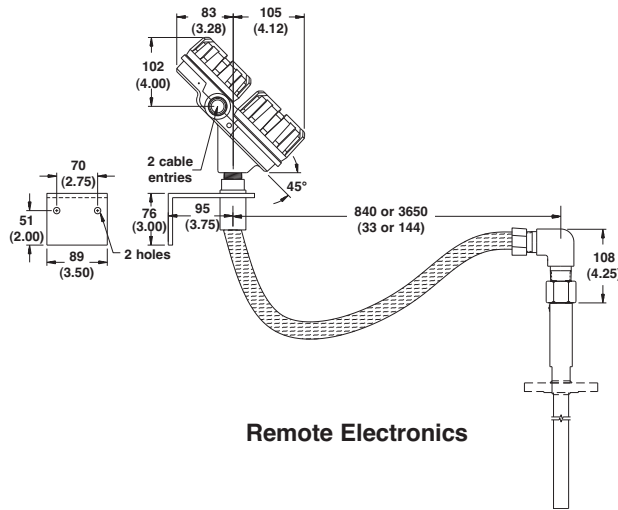

**Remote Electronics**

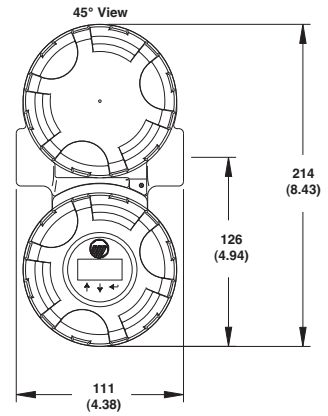

**Eclipse Housing,  
(45° View)**

## EXPEDITE SHIP PLAN (ESP)

Several Eclipse Guided Wave Radar Transmitters are available for quick shipment, within max. 4 weeks after factory receipt of purchase order, through the Expedite Ship Plan (ESP).

Models covered by ESP service are conveniently colour coded in the selection data charts.

To take advantage of ESP, simply match the colour coded model number codes (standard dimensions apply).

ESP service may not apply to orders of ten units or more. Contact your local representative for lead times on larger volume orders, as well as other products and options.

## SELECTION DATA

**A complete measuring system consists of:**

1. Eclipse transmitter head/electronics
2. Eclipse 705 GWR probe
3. Free of charge: Magnetrol master C.D. with Eclipse 705 DTM (PACTware™). Order code: **090-BE59-200** (included in each order).
4. OPTION:
  - TFE spacer for single rod metal GWR probes; order code: **089-9114-001** (7MF-A), **089-9114-002** (7MF-B), **089-9114-003** (7MF-C)
  - PEEK spacer for single rod 7MJ GWR probe; order code: **089-9114-005** (7MJ-A), **089-9114-006** (7MJ-B), **089-9114-007** (7MJ-C)
  - Additional weight for 7M1 GWR probe; order code: **089-9120-001**
  - Additional weight for 7M7 GWR probe; order code: **089-9121-001**
  - Additional weight for 7M2 GWR probe; order code: **004-8778-001** (requires 2 x **010-1731-001**: cable clamps)
  - Additional weight for 7M5 GWR probe; order code: **004-8778-002** (requires 2 x **010-1731-001**: cable clamps)

## ELECTRICAL WIRING

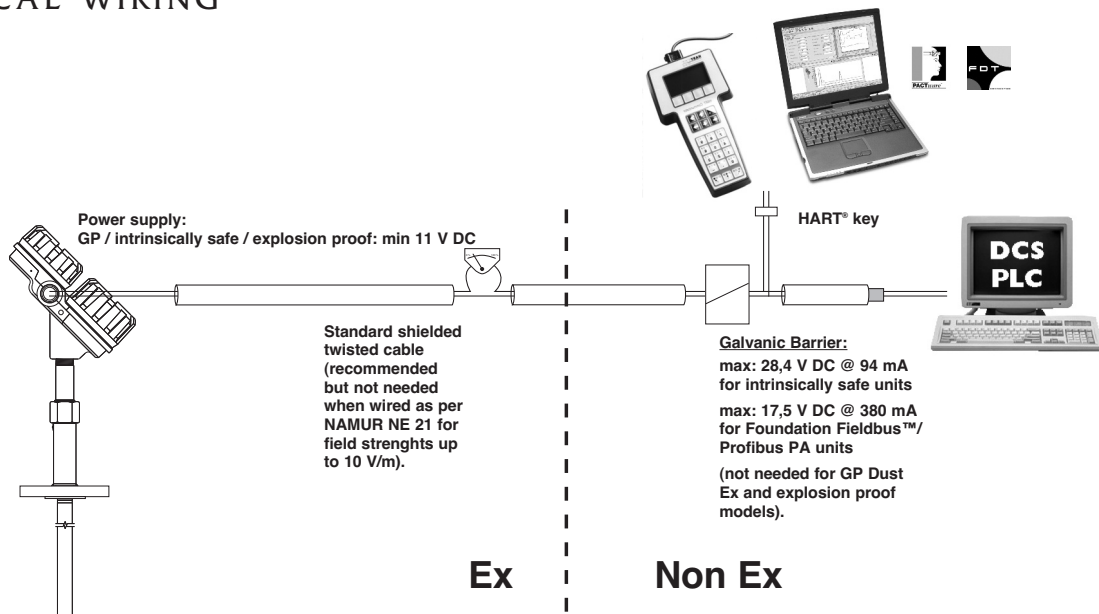

**1. Order code for ECLIPSE 705 transmitter head/electronics**

BASIC MODEL NUMBER

7 0 5	Eclipse 705 guided wave radar transmitter
-------	---

POWER

5	24 V DC, two wire loop powered
---	--------------------------------

SIGNAL OUTPUT AND ELECTRONICS

1 0	4-20 mA with Hart – standard electronics (SFF of 85.4%)
1 A	4-20 mA with Hart – SIL enhanced electronics (SFF of 91%)
2 0	Foundation Fieldbus™ communication
3 0	Profibus PA™ communication

ACCESSORIES

A	Digital display and keypad
0	Blind transmitter (no display/keypad)

MOUNTING / HOUSING MATERIAL / CLASSIFICATION (Consult factory for FM/CSA approvals)

**Integral mount amplifiers**

Cast aluminium

1 1	Weatherproof area (& I.S. FM/CSA)
A 1	ATEX intrinsically safe and ATEX FISCO area
C 1	ATEX and Foundation Fieldbus explosion proof area
E 1	ATEX non sparking and ATEX FNICO area

Cast SST

1 2	Weatherproof area (& I.S. FM/CSA)
A 2	ATEX intrinsically safe and ATEX FISCO area
C 2	ATEX and Foundation Fieldbus explosion proof area
E 2	ATEX non sparking and ATEX FNICO area

**85 cm (33") remote mount amplifiers.** Consult factory for remote mount units up to 3,6 m (12 ft)

Cast aluminium

2 1	Weatherproof area (& I.S. FM/CSA)
B 1	ATEX intrinsically safe and ATEX FISCO area
D 1	ATEX and Foundation Fieldbus explosion proof area
F 1	ATEX non sparking and ATEX FNICO area

Cast SST

2 2	Weatherproof area (& I.S. FM/CSA)
B 2	ATEX intrinsically safe and ATEX FISCO area
D 2	ATEX and Foundation Fieldbus explosion proof area
F 2	ATEX non sparking and ATEX FNICO area

CABLE ENTRY

1	M20 x 1.5 (2 entries - one plugged)
0	3/4" NPT (2 entries - one plugged)

7	0	5	5				
---	---	---	---	--	--	--	--

**complete order code for ECLIPSE 705 transmitter head/electronics**

# MOUNTING

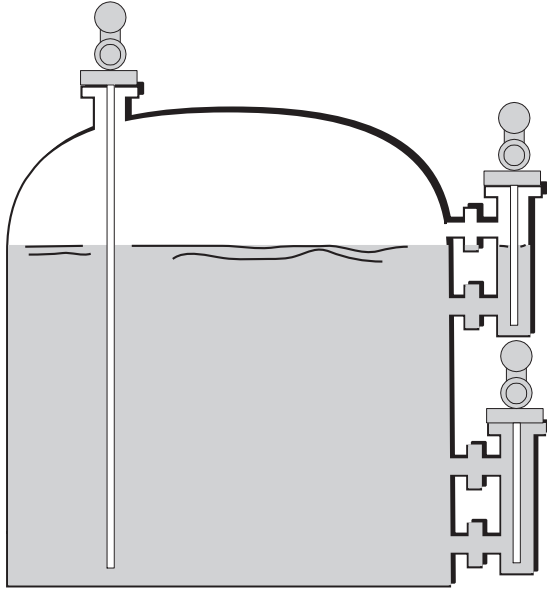

## Overfill safe and Overfill proof

Eclipse 7MR, 7MM, 7MT and 7MN coaxial type GWR probes are “overfill safe” in use and “Overfill proof” certified.

**Overfill safe** means that the unit is capable to measure up to the process connection. Units with “non overfill safe” probes use software to ignore level readings in the blocking distance or transitioning zone. When level rises too high in this zone, the unit may consider the end of probe reflection as the real level and may report an empty vessel instead of an overflowing vessel.

**Overfill proof** protection (such as WHG or VLAREM) certifies reliable operation when the transmitter is used as overfill alarm but assumes that the installation is designed in such way that the vessel/ cage cannot overflow.

## DIMENSIONS in mm (inches)

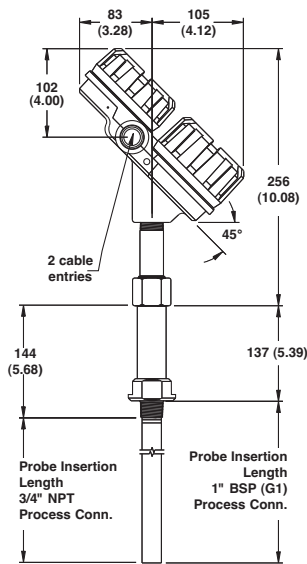

**7MR / 7MT  
with threaded  
connection**

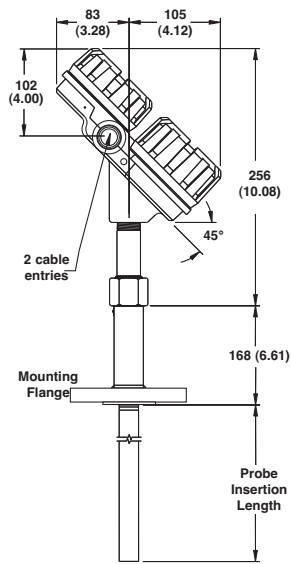

**7MR / 7MT  
with flanged connection**

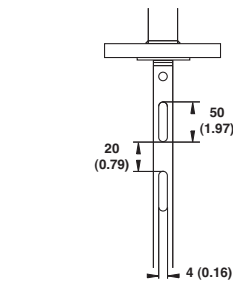

**Slots for 7MR-A  
(order per “x” description)**

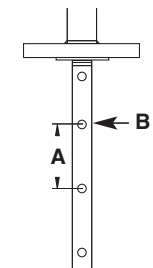

**Venting holes  
for level**

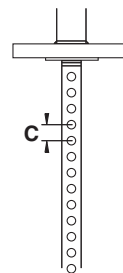

**Venting holes  
for interface**

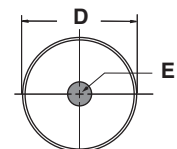

**Coaxial GWR Probe,  
End View**

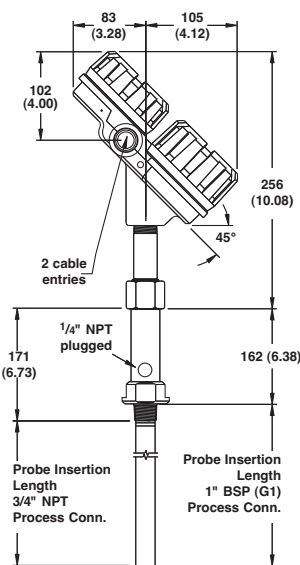

**7MM / 7MN  
with flushing  
connection**

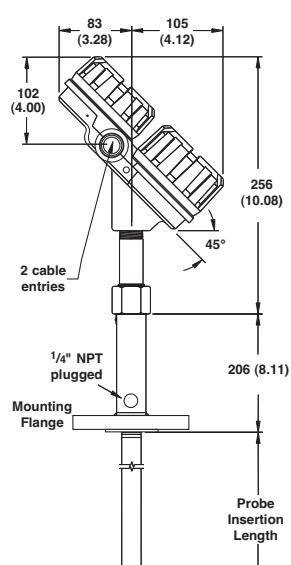

**7MM / 7MN  
with flushing  
connection**

Dim.	Small coax	Large coax <sup>①</sup>
A	305 (12)	305 (12)
B	Ø 6,4 (0.25)	Ø 12,7 (0.5)
C	19 (0.75)	25,4 (1)
D	22,5 (0.88)	45 (1.75) - SST 49 (1.29) - HC and Monel
E	8 (0.31)	16 (0.63)

<sup>①</sup> Consult bulletin 57-102

## 2. Order code for ECLIPSE 705 Coaxial GWR probe

BASIC MODEL NUMBER

**GWR probe suited for external cage and/or in-tank mounting**

7 M R	GWR probe for level	Er ≥ 1,4 - WHG approved
7 M M	GWR probe for level with flushing connection	Er ≥ 1,4 - WHG approved
7 M T	GWR probe for interface	upper liq: Er ≥ 1,4 and ≤ 5 / lower liq: ≥ 15 - WHG approved
7 M N	GWR probe for interface with flushing connection	upper liq: Er ≥ 1,4 and ≤ 5 / lower liq: ≥ 15 - WHG approved

MATERIAL OF CONSTRUCTION - wetted parts (including process connection flange when applicable)

A	316/316L (1.4401/1.4404) stainless steel with Teflon® spacers
B	Hastelloy C (2.4819)
C	Monel (2.4360)

PROCESS CONNECTION - SIZE/TYPE (consult factory for other process connections)

**Threaded**

1 1	3/4" NPT thread	2 2	1" BSP (G1) thread
-----	-----------------	-----	--------------------

**ANSI flanges**

2 3	1" 150 lbs. ANSI RF	4 5	2" 600 lbs. ANSI RF
2 4	1" 300 lbs. ANSI RF	5 3	3" 150 lbs. ANSI RF
2 5	1" 600 lbs. ANSI RF	5 4	3" 300 lbs. ANSI RF
3 3	1 1/2" 150 lbs. ANSI RF	5 5	3" 600 lbs. ANSI RF
3 4	1 1/2" 300 lbs. ANSI RF	6 3	4" 150 lbs. ANSI RF
3 5	1 1/2" 600 lbs. ANSI RF	6 4	4" 300 lbs. ANSI RF
4 3	2" 150 lbs. ANSI RF	6 5	4" 600 lbs. ANSI RF
4 4	2" 300 lbs. ANSI RF		

**EN/DIN flanges**

B B	DN 25, PN 16/25/40 EN 1092-1 Type A	E A	DN 80, PN 16 EN 1092-1 Type A
B C	DN 25, PN 63/100 EN 1092-1 Type B2	E B	DN 80, PN 25/40 EN 1092-1 Type A
C B	DN 40, PN 16/25/40 EN 1092-1 Type A	E D	DN 80, PN 63 EN 1092-1 Type B2
C C	DN 40, PN 63/100 EN 1092-1 Type B2	E E	DN 80, PN 100 EN 1092-1 Type B2
D A	DN 50, PN 16 EN 1092-1 Type A	F A	DN 100, PN 16 EN 1092-1 Type A
D B	DN 50, PN 25/40 EN 1092-1 Type A	F B	DN 100, PN 25/40 EN 1092-1 Type A
D D	DN 50, PN 63 EN 1092-1 Type B2	F D	DN 100, PN 63 EN 1092-1 Type B2
D E	DN 50, PN 100 EN 1092-1 Type B2	F E	DN 100, PN 100 EN 1092-1 Type B2

**Torque tube mating flanges ①**

T T	300/600 lbs Fisher (249B/259B) in carbon steel - as per dimensions of Figure 1 on page 4
T U	300/600 lbs Fisher (249C) in stainless steel - as per dimensions of Figure 2 on page 4
U T	300/600 lbs Masoneilan flange in carbon steel - as per dimensions of Figure 3 on page 4
U U	300/600 lbs Masoneilan flange in stainless steel - as per dimensions of Figure 3 on page 4

① Always check dimensions if no ANSI/DIN flanges are used.

**PROCESS SEAL - MATERIAL ①**

0	Viton GFLT seal - for universal use	-40 °C (-40 °F) / +200 °C (+400 °F)
2	Kalrez 4079 seal - for aggressive media	-40 °C (-40 °F) / +200 °C (+400 °F)
8	Aegis PF 128 seal - for steam <sup>②</sup> and NACE applications	-20 °C (-4 °F) / +200 °C (+400 °F)

① Consult factory for alternative seal materials. For Hydro Fluoric use, select X7MR or X7MT, "X" = for HF use".  
For ammonia/chlorine applications use the 7MD GWR probe.

② Max +150 °C (300 °F) for use on steam.

**INSERTION LENGTH – specify per 1 cm (0.39") increments**

0 6 0	min 60 cm (24") insertion length
6 1 0	max 610 cm (240") insertion length

Consult factory for insertion lengths < 60 cm (24")



**complete code for ECLIPSE 705 Coaxial GWR probe**

# MOUNTING

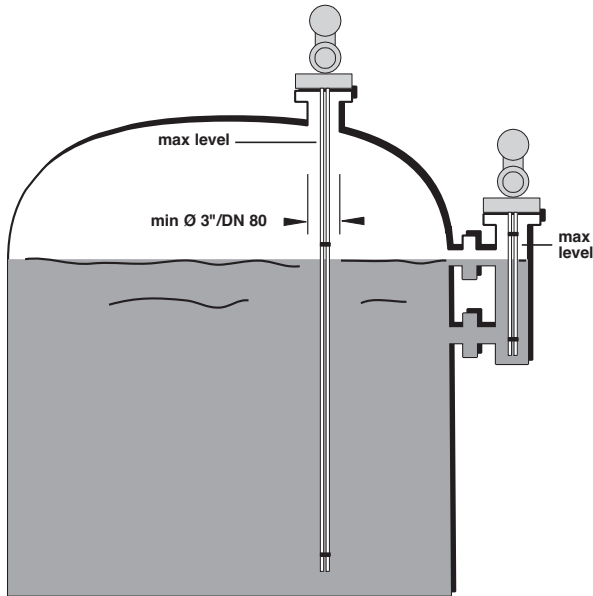

## Overflow safe and Overflow protection

Eclipse twin rod GWR probes use software to ignore level readings in the transitioning zone at the top of the GWR probe. The maximum level is a minimum of 150 mm (6") below the process connection. This may include utilizing a nozzle or spool piece to raise the probe. Twin rod probes are overflow proof certified but not overflow safe in use.

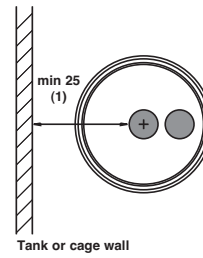

signal propagation

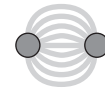

end view

## Nozzles:

The nozzle should be min. Ø 3"/DN80.

# DIMENSIONS in mm (inches)

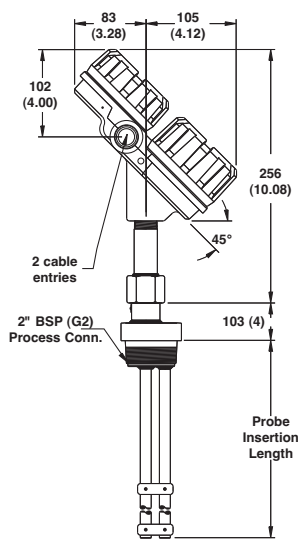

**7MB  
with threaded  
2" BSP (G2) connection**

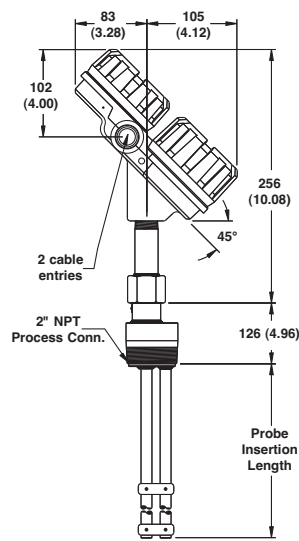

**7MB  
with threaded  
2" NPT connection**

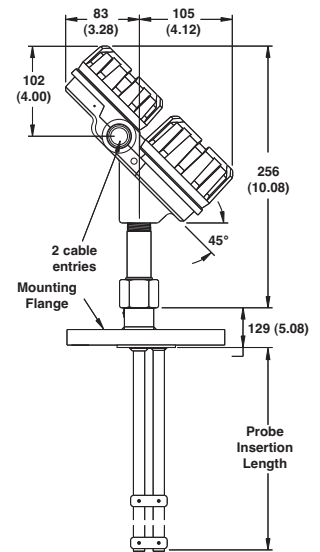

**7MB  
with flanged  
connection**

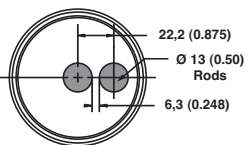

**Twin Rod GWR Probe,  
End View**

**2. Order code for ECLIPSE 705 Twin Rod GWR probe**

BASIC MODEL NUMBER

**GWR probe for in-tank mounting only**

7	M	B	Twin Rod GWR probe for liquid level	(dielectric range: $\geq 1,9$ ) - WHG approved
---	---	---	-------------------------------------	--

MATERIAL OF CONSTRUCTION - wetted parts (including process connection flange when applicable)

A	316/316L (1.4401/1.4404) stainless steel with TFE spacers
B	Hastelloy C (2.4819) with TFE spacers
C	Monel (2.4360) with TFE spacers

PROCESS CONNECTION - SIZE/TYPE

**Threaded**

4	1	2" NPT thread
4	2	2" BSP (G2) thread

**ANSI flanges** (consult factory for 2" process connections)

5	3	3"	150 lbs. ANSI raised face flange
5	4	3"	300 lbs. ANSI raised face flange
6	3	4"	150 lbs. ANSI raised face flange
6	4	4"	300 lbs. ANSI raised face flange

**EN/DIN flanges** (consult factory for DN 50 process connections)

E	A	DN 80, PN 16	EN 1092-1 Type A
E	B	DN 80, PN 25/40	EN 1092-1 Type A
E	D	DN 80, PN 63	EN 1092-1 Type B2
F	A	DN 100, PN 16	EN 1092-1 Type A
F	B	DN 100, PN 25/40	EN 1092-1 Type A
F	D	DN 100, PN 63	EN 1092-1 Type B2

**Torque tube mating flanges** <sup>①</sup>

T	T	300/600 lbs Fisher (249B/259B) in carbon steel - as per dimensions of Figure 1 on page 4
T	U	300/600 lbs Fisher (249C) in stainless steel - as per dimensions of Figure 2 on page 4
U	T	300/600 lbs Masoneilan flange in carbon steel - as per dimensions of Figure 3 on page 4
U	U	300/600 lbs Masoneilan flange in stainless steel - as per dimensions of Figure 3 on page 4

<sup>①</sup> Always check dimensions if no ANSI/DIN flanges are used.

PROCESS SEAL - MATERIAL <sup>①</sup>

0	Viton GFLT seal - for universal use	-40 °C (-40 °F) / +200 °C (+400 °F)
2	Kalrez 4079 seal - for aggressive media	-40 °C (-40 °F) / +200 °C (+400 °F)
8	Aegis PF 128 seal - for NACE applications	-20 °C (-4 °F) / +200 °C (+400 °F)

<sup>①</sup> Consult factory for alternative seal materials. For Hydro Fluoric use, select X7MR or X7MT, "X = for HF use". For ammonia/chlorine applications use the 7MD GWR probe.

INSERTION LENGTH – specify per 1 cm (0.39") increments (up to 22 m (75') with twin cable GWR probe, see page 18 and 19)

0	6	0	min 60 cm (24") insertion length
6	1	0	max 610 cm (240") insertion length



**complete order code for ECLIPSE 705 Twin Rod GWR probe**

# MOUNTING

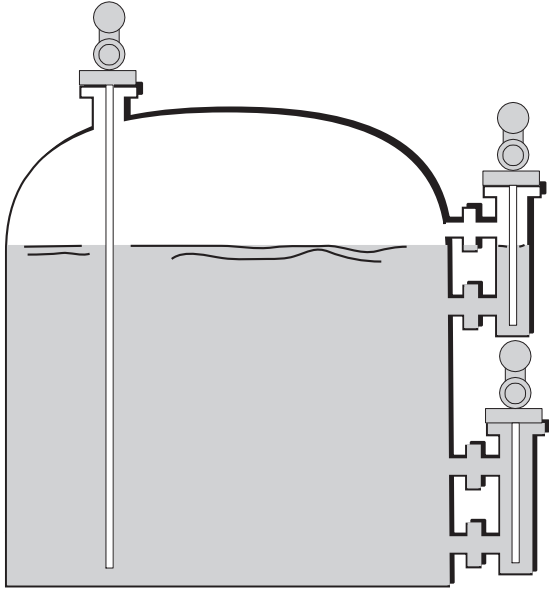

## Overfill safe and Overfill protection

Eclipse 7ML and 7MD coaxial type GWR probes are “overfill safe” in use and “Overfill proof” certified.

**Overfill safe** means that the unit is capable to measure up to the process connection. Units with “non overfill safe” probes use software to ignore level readings in the blocking distance or transitioning zone. When level rises too high in this zone, the unit may consider the end of probe reflection as the real level and may report an empty vessel instead of an overflowing vessel.

**Overfill proof** protection (such as WHG or VLAREM) certifies reliable operation when the transmitter is used as overfill alarm but assumes that the installation is designed in such way that the vessel/ cage cannot overflow.

## DIMENSIONS in mm (inches)

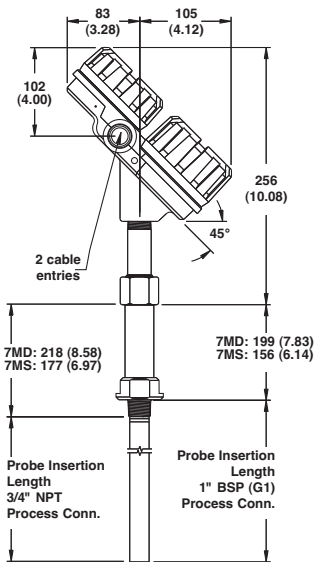

**7MD/7MS with threaded connection**

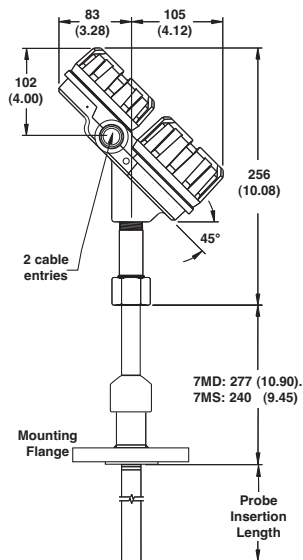

**7MD/7MS with flanged connection**

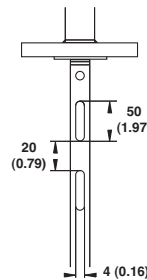

**Slots for 7MD - A/V/W (order per “x” description)**

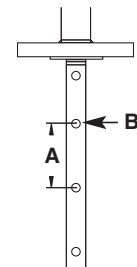

**Venting holes for all**

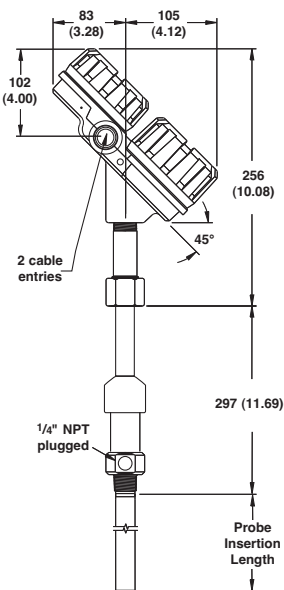

**7ML with threaded connection**

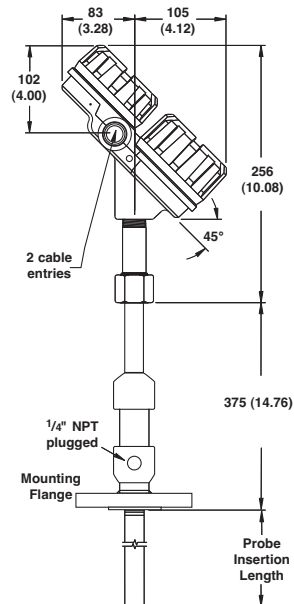

**7ML with flanged connection**

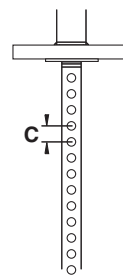

**Venting holes for 7MD/7ML (order per “x” description)**

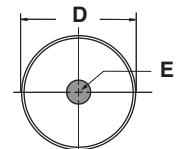

**Coaxial GWR Probe, End View**

Dim.	Small coax	Large coax <sup>①</sup>
A	305 (12)	305 (12)
B	Ø 6,4 (0.25)	Ø 12,7 (0.5)
C	19 (0.75)	25,4 (1)
D	22,5 (0.88)	45 (1.75) - SST 49 (1.29) - HC and Monel
E	8 (0.31)	16 (0.63)

<sup>①</sup> Consult bulletin 57-102

**2. Order code for ECLIPSE 705 High Temperature / High Pressure Coaxial GWR probe**

7 M D	HTHP GWR probe for level	WHG approved
7 M L	HTHP GWR probe for level with flushing connection	WHG approved

**MATERIAL OF CONSTRUCTION (all wetted parts) AND MIN. DIELECTRICS**

W	316/316L (1.4401/1.4404) stainless steel with Teflon® spacers	min. dielectrics: ≥ 1,4 / max +200 °C
V	316/316L (1.4401/1.4404) SST with H. Temp PEEK® spacers	min. dielectrics: ≥ 1,7 / max +345 °C
A	316/316L (1.4401/1.4404) SST with ceramic spacers	min. dielectrics: ≥ 2,0 / max +430 °C
B	Hastelloy C (2.4819) with ceramic spacers	min. dielectrics: ≥ 2,0 / max +430 °C
C	Monel (2.4360) with ceramic spacers	min. dielectrics: ≥ 2,0 / max +430 °C

**PROCESS CONNECTION - SIZE/TYPE (consult factory for other process connections)**

**Threaded**

1 1	3/4" NPT thread
-----	-----------------

2 2	1" BSP (G1) thread
-----	--------------------

**ANSI flanges**

2 3	1"	150 lbs. ANSI RF
2 4	1"	300 lbs. ANSI RF
2 5	1"	600 lbs. ANSI RF
2 K	1"	600 lbs. ANSI RJ
2 L	1"	900 lbs. ANSI RJ
3 3	1 1/2"	150 lbs. ANSI RF
3 4	1 1/2"	300 lbs. ANSI RF
3 5	1 1/2"	600 lbs. ANSI RF
3 K	1 1/2"	600 lbs. ANSI RJ
3 M	1 1/2"	900/1500 lbs. ANSI RJ
3 N	1 1/2"	2500 lbs. ANSI RJ
4 3	2"	150 lbs. ANSI RF
4 4	2"	300 lbs. ANSI RF
4 5	2"	600 lbs. ANSI RF
4 K	2"	600 lbs. ANSI RJ
4 M	2"	900/1500 lbs. ANSI RJ

4 N	2"	2500 lbs. ANSI RJ
5 3	3"	150 lbs. ANSI RF
5 4	3"	300 lbs. ANSI RF
5 5	3"	600 lbs. ANSI RF
5 K	3"	600 lbs. ANSI RJ
5 L	3"	900 lbs. ANSI RJ
5 M	3"	1500 lbs. ANSI RJ
5 N	3"	2500 lbs. ANSI RJ
6 3	4"	150 lbs. ANSI RF
6 4	4"	300 lbs. ANSI RF
6 5	4"	600 lbs. ANSI RF
6 K	4"	600 lbs. ANSI RJ
6 L	4"	900 lbs. ANSI RJ
6 M	4"	1500 lbs. ANSI RJ
6 N	4"	2500 lbs. ANSI RJ

**EN/DIN flanges**

B B	DN 25, PN 16/25/40	EN 1092-1 Type A
B C	DN 25, PN 63/100	EN 1092-1 Type B2
B F	DN 25, PN 160	EN 1092-1 Type B2
C B	DN 40, PN 16/25/40	EN 1092-1 Type A
C C	DN 40, PN 63/100	EN 1092-1 Type B2
C F	DN 40, PN 160	EN 1092-1 Type B2
C G	DN 40, PN 250	EN 1092-1 Type B2
C H	DN 40, PN 320	EN 1092-1 Type B2
C J	DN 40, PN 400	EN 1092-1 Type B2
D A	DN 50, PN 16	EN 1092-1 Type A
D B	DN 50, PN 25/40	EN 1092-1 Type A
D D	DN 50, PN 63	EN 1092-1 Type B2
D E	DN 50, PN 100	EN 1092-1 Type B2
D F	DN 50, PN 160	EN 1092-1 Type B2
D G	DN 50, PN 250	EN 1092-1 Type B2
D H	DN 50, PN 320	EN 1092-1 Type B2

D J	DN 50, PN 400	EN 1092-1 Type B2
E A	DN 80, PN 16	EN 1092-1 Type A
E B	DN 80, PN 25/40	EN 1092-1 Type A
E D	DN 80, PN 63	EN 1092-1 Type B2
E E	DN 80, PN 100	EN 1092-1 Type B2
E F	DN 80, PN 160	EN 1092-1 Type B2
E G	DN 80, PN 250	EN 1092-1 Type B2
E H	DN 80, PN 320	EN 1092-1 Type B2
E J	DN 80, PN 400	EN 1092-1 Type B2
F A	DN 100, PN 16	EN 1092-1 Type A
F B	DN 100, PN 25/40	EN 1092-1 Type A
F D	DN 100, PN 63	EN 1092-1 Type B2
F E	DN 100, PN 100	EN 1092-1 Type B2
F F	DN 100, PN 160	EN 1092-1 Type B2
F G	DN 100, PN 250	EN 1092-1 Type B2
F H	DN 100, PN 320	EN 1092-1 Type B2
F J	DN 100, PN 400	EN 1092-1 Type B2

**Torque tube mating flanges (always check dimensions if no ANSI / EN/DIN flanges are used)**

T T	300/600 lbs Fisher (249B/259B) in carbon steel - as per dimensions of Figure 1 on page 4
T U	300/600 lbs Fisher (249C) in stainless steel - as per dimensions of Figure 2 on page 4
U T	300/600 lbs Masoneilan flange in carbon steel - as per dimensions of Figure 3 on page 4
U U	300/600 lbs Masoneilan flange in stainless steel - as per dimensions of Figure 3 on page 4

**PROCESS SEAL MATERIAL**

N	Borosilicate / Inconel® X-750 seal – for non steam applications	-196 °C (-320 °F) / +400 °C (+750 °F)①
---	---	--

① 7MD-W: max +200 °C (+400 °F) – 7MD-V: max +345 °C (+650 °F)

**INSERTION LENGTH – specify per 1 cm (0.39") increments**

0 6 0	min 60 cm (24") insertion length
6 1 0	max 610 cm (240") insertion length

Consult factory for insertion lengths < 60 cm (24")



**complete order code for ECLIPSE 705 High Temperature / High Pressure Coaxial GWR probe**

**2. Order code for ECLIPSE 705 small Coaxial GWR probe for saturated steam**

7	M	S	Coaxial GWR probe for saturated steam applications, incl. steam compensation reference		
---	---	---	--	--	--

**MATERIAL OF CONSTRUCTION**

A	316/316L (1.4401/1.4404)			
---	--------------------------	--	--	--

PROCESS CONNECTION - SIZE/TYPE (consult factory for other process connections)  
Flanges are of solid material per selected material of construction.

**Threaded**

1	1	3/4" NPT thread	
---	---	-----------------	--

2	2	1" BSP (G1) thread	
---	---	--------------------	--

**ANSI flanges**

2	3	1"	150 lbs. ANSI RF
2	4	1"	300 lbs. ANSI RF
2	5	1"	600 lbs. ANSI RF
2	K	1"	600 lbs. ANSI RJ
2	L	1"	900 lbs. ANSI RJ
3	3	1 1/2"	150 lbs. ANSI RF
3	4	1 1/2"	300 lbs. ANSI RF
3	5	1 1/2"	600 lbs. ANSI RF
3	K	1 1/2"	600 lbs. ANSI RJ
3	M	1 1/2"	900/1500 lbs. ANSI RJ
3	N	1 1/2"	2500 lbs. ANSI RJ
4	3	2"	150 lbs. ANSI RF
4	4	2"	300 lbs. ANSI RF
4	5	2"	600 lbs. ANSI RF
4	K	2"	600 lbs. ANSI RJ
4	M	2"	900/1500 lbs. ANSI RJ

4	N	2"	2500 lbs. ANSI RJ
5	3	3"	150 lbs. ANSI RF
5	4	3"	300 lbs. ANSI RF
5	5	3"	600 lbs. ANSI RF
5	K	3"	600 lbs. ANSI RJ
5	L	3"	900 lbs. ANSI RJ
5	M	3"	1500 lbs. ANSI RJ
5	N	3"	2500 lbs. ANSI RJ
6	3	4"	150 lbs. ANSI RF
6	4	4"	300 lbs. ANSI RF
6	5	4"	600 lbs. ANSI RF
6	K	4"	600 lbs. ANSI RJ
6	L	4"	900 lbs. ANSI RJ
6	M	4"	1500 lbs. ANSI RJ
6	N	4"	2500 lbs. ANSI RJ

**ENDIN flanges**

B	B	DN 25, PN 16/25/40	EN 1092-1 Type A
B	C	DN 25, PN 63/100	EN 1092-1 Type B2
B	F	DN 25, PN 160	EN 1092-1 Type B2
C	B	DN 40, PN 16/25/40	EN 1092-1 Type A
C	C	DN 40, PN 63/100	EN 1092-1 Type B2
C	F	DN 40, PN 160	EN 1092-1 Type B2
C	G	DN 40, PN 250	EN 1092-1 Type B2
C	H	DN 40, PN 320	EN 1092-1 Type B2
C	J	DN 40, PN 400	EN 1092-1 Type B2
D	A	DN 50, PN 16	EN 1092-1 Type A
D	B	DN 50, PN 25/40	EN 1092-1 Type A
D	D	DN 50, PN 63	EN 1092-1 Type B2
D	E	DN 50, PN 100	EN 1092-1 Type B2
D	F	DN 50, PN 160	EN 1092-1 Type B2
D	G	DN 50, PN 250	EN 1092-1 Type B2
D	H	DN 50, PN 320	EN 1092-1 Type B2

D	J	DN 50, PN 400	EN 1092-1 Type B2
E	A	DN 80, PN 16	EN 1092-1 Type A
E	B	DN 80, PN 25/40	EN 1092-1 Type A
E	D	DN 80, PN 63	EN 1092-1 Type B2
E	E	DN 80, PN 100	EN 1092-1 Type B2
E	F	DN 80, PN 160	EN 1092-1 Type B2
E	G	DN 80, PN 250	EN 1092-1 Type B2
E	H	DN 80, PN 320	EN 1092-1 Type B2
E	J	DN 80, PN 400	EN 1092-1 Type B2
F	A	DN 100, PN 16	EN 1092-1 Type A
F	B	DN 100, PN 25/40	EN 1092-1 Type A
F	D	DN 100, PN 63	EN 1092-1 Type B2
F	E	DN 100, PN 100	EN 1092-1 Type B2
F	F	DN 100, PN 160	EN 1092-1 Type B2
F	G	DN 100, PN 250	EN 1092-1 Type B2
F	H	DN 100, PN 320	EN 1092-1 Type B2
F	J	DN 100, PN 400	EN 1092-1 Type B2

**Proprietary flanges <sup>①</sup>**

T	T	300/600 lbs Fisher (249B/259B) in carbon steel - as per dimensions of Figure 1 on page 4	
T	U	300/600 lbs Fisher (249C) in stainless steel - as per dimensions of Figure 2 on page 4	
U	T	300/600 lbs Masoneilan flange in carbon steel - as per dimensions of Figure 3 on page 4	
U	U	300/600 lbs Masoneilan flange in stainless steel - as per dimensions of Figure 3 on page 4	

<sup>①</sup> Always check dimensions if no ANSI/DIN flanges are used.

**PROCESS SEAL MATERIAL**

8	Dynamic steam seal (Aegis PF 128 / PEEK)		
---	--	--	--

**INSERTION LENGTH – specify per 1 cm (0.39") increments**

0	6	0	min 60 cm (24") insertion length with single bottom spacer
4	5	0	max 450 cm (177") up to 250 (98") with spacers per each 60 cm (24")

7	M	S	A			8			
---	---	---	---	--	--	---	--	--	--

**complete order code for ECLIPSE 705 Coaxial GWR probe for saturated steam**

# MOUNTING CONSIDERATIONS

## 1. Turbulence

### For 7MF/7M1/7M2/7MJ (single rod/cable)

The bottom of the probe should be stabilized if turbulence will cause a deflection of more than 75 mm at 3 m (3' at 10') of length. The probe should not make contact with a metal tank. A TFE bottom spacer for 7MF GWR probes or PEEK spacer for 7MJ is optional.

## 2. Nozzles: do not restrict the performance by ensuring the following:

### For 7MF/7M1/7M2/7MJ (single rod/cable):

1. Nozzle must be 50 mm (2") or larger diameter.
2. Nozzle inside diameter (**A**) should be  $\geq$  to nozzle height (**B**). If this is not the case, it is recommended to adjust BLOCKING DISTANCE and/or SENSITIVITY settings.

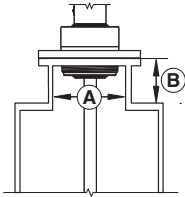

Correct installation

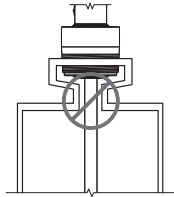

Pipe reducers should not be used

### For 7M5/7M7 (twin cable):

1. Nozzle should be DN80 (3") diameter or larger.
2. For nozzles < DN80 (3") diameter, the bottom of the inactive section of the probe should be flush with the bottom of the nozzle or extend into the vessel.

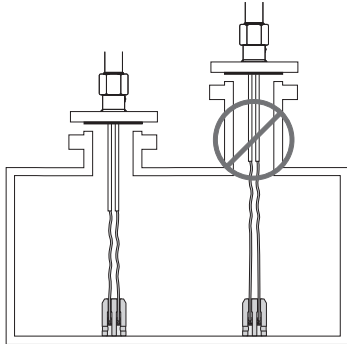

## 3. Metallic (conductive) obstructions in tank.

### For 7MF/7M1/7M2 (single cable)

A metal stillwell/cage of max. 6"/DN150 size or a metal tank wall within 150 mm of the probe mounting will allow the unit to operate accurately in media with dielectrics down to  $\epsilon_r$  1.9.

Objects in the proximity can cause erroneous readings

### For 7M5/7M7 (twin cable)

Mount the probe more than 25 mm (1") from any metallic object/vessel wall.

Distance to probe	Acceptable objects
< 150 mm (6")	Continuous, smooth, parallel, conductive surface (e.g. metal tank wall); probe should not touch tank wall
> 150 mm (6")	< 1"/DN25 diameter pipe and beams, ladder rungs
> 300 mm (12")	< 3"/DN80 diameter pipe and beams, concrete walls
> 450 mm (18")	All remaining objects

## 4. Non-metallic vessels

### For 7MF/7M1/7M2/7MJ (single rod/cable)

Flange (metal) mounting is recommended for optimum performance.

## High level shutdown / Overfill protection

Special consideration is necessary in any high level shutdown / overfill protection application where single rod GWR probes are used. To ensure proper measurement, the guided wave radar probe should be installed so the maximum overfill level is at a minimum of 120 mm (4.8") up to 910 mm (36") – blocking distance depending application below the process connection. Consult factory for further information.

## Single rod probes

Single element GWR probes act quite differently from coaxial and twin element designs. The pulses of energy develop between the center rod and the mounting nut or flange; the pulse propagates down the rod as it references its ground at the top of the tank. The efficiency of the pulse "launch" is directly related to how much metallic surface exists around it at the top of the vessel.

This figure shows the single element design and how the pulse expands into a teardrop shape as it propagates away from the top of the tank (ground reference). This Single element configuration is the least efficient of the three with minimum dielectric detection approximately  $\epsilon_r > 10$ . This dielectric performance improves considerably ( $\epsilon_r > 1.9$ ) when the probe is installed between 2–6" (50–150 mm) of a metal tank wall or in a cage/bridle. Because the design is "open", it exhibits two strong tendencies. First, it is the most forgiving of coating and buildup. (The PFA-insulated probe is the best choice for severe coating). Secondly, it is most affected by proximity issues. It is important to note that a parallel metal wall INCREASES its performance while a singular, metal object protruding near the probe may be improperly detected as a liquid level.

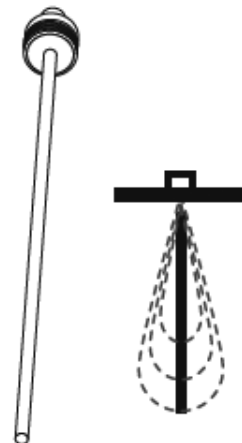

Single Rod Probe

**DIMENSIONS in mm (inches)**

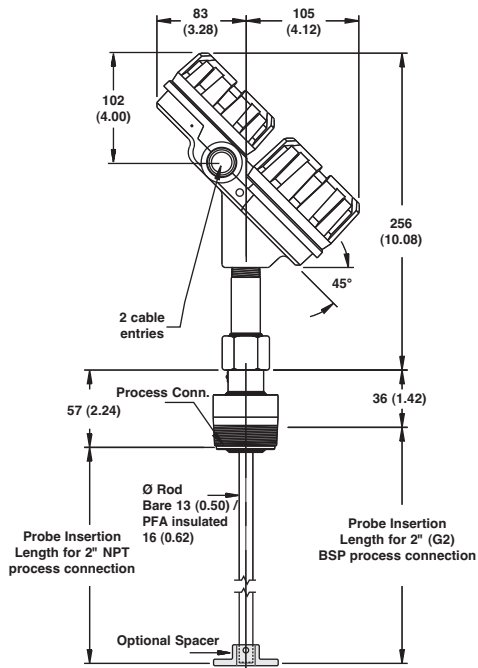

**7MF/7MJ  
with threaded connection  
max. 6,1 m (240")**

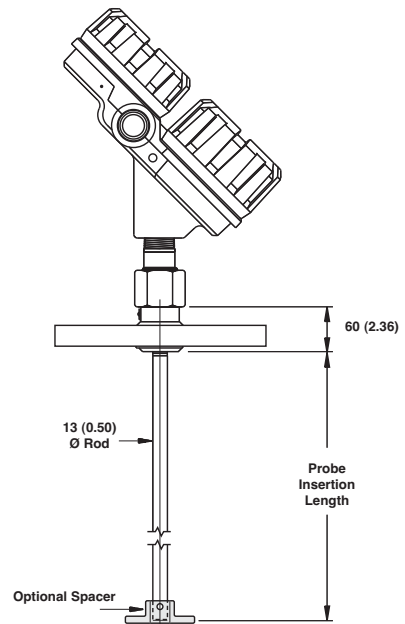

**7MF/7MJ  
with flanged connection  
max. 6,1 m (240")**

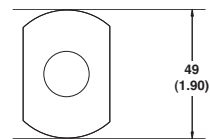

**Spacer (end view)**

**MOUNTING**

Consult mounting considerations on page 15

**2. Order code for ECLIPSE 705 GWR probe for liquids (for in-tank mounting only)**

- 316/316L (1.4401/1.4404) material for standard applications
- Hastelloy C (2.4819) or Monel (2.4360) for extreme aggressive media
- PFA insulated for applications with excessive coating / build up.

**BASIC MODEL NUMBER**

7 M F	Standard single rod GWR probe	(dielectric range: $\geq 1,9/10$ ) <sup>①</sup>
7 M J	High temperature / high pressure single rod GWR probe	(dielectric range: $\geq 1,9/10$ ) <sup>①</sup>

<sup>①</sup> For dielectric range  $\geq 1,9$  and  $< 10$ , probe must be mounted within 50 - 150 mm (2" - 6") distance from the tank wall or in a cage or bridle. See mounting considerations on page 5

**MATERIAL OF CONSTRUCTION**

A	316/316L (1.4401/1.4404) stainless steel	for 7MF/7MJ
B	Hastelloy C (2.4819)	for 7MF/7MJ
C	Monel (2.4360)	for 7MF/7MJ
4	PFA insulated 316/316L (1.4401/1.4404) SST	for 7MF

**PROCESS CONNECTION - SIZE/TYPE**

**Threaded**

4 1	2" NPT thread
4 2	2" BSP (G2) thread

**ANSI flanged** <sup>①</sup>

4 3	2" 150 lbs. ANSI RF
4 4	2" 300 lbs. ANSI RF
4 5	2" 600 lbs. ANSI RF
4 K	2" 600 lbs. ANSI RJ
4 M	2" 900/1500 lbs. ANSI RJ
5 3	3" 150 lbs. ANSI RF flange
5 4	3" 300 lbs. ANSI RF flange
5 5	3" 600 lbs. ANSI RF flange
5 K	3" 600 lbs. ANSI RJ flange
5 L	3" 900 lbs. ANSI RJ flange
5 M	3" 1500 lbs. ANSI RJ flange
6 3	4" 150 lbs. ANSI RF flange
6 4	4" 300 lbs. ANSI RF flange
6 5	4" 600 lbs. ANSI RF flange
6 K	4" 600 lbs. ANSI RJ flange
6 L	4" 900 lbs. ANSI RJ flange
6 M	4" 1500 lbs. ANSI RJ flange

**EN/DIN flanged** <sup>①</sup>

D A	DN 50, PN 16	EN 1092-1 Type A
D B	DN 50, PN 25/40	EN 1092-1 Type A
D D	DN 50, PN 63	EN 1092-1 Type B2
D E	DN 50, PN 100	EN 1092-1 Type B2
D F	DN 50, PN 160	EN 1092-1 Type B2
D G	DN 50, PN 250	EN 1092-1 Type B2
E A	DN 80, PN 16	EN 1092-1 Type A
E B	DN 80, PN 25/40	EN 1092-1 Type A
E D	DN 80, PN 63	EN 1092-1 Type B2
E E	DN 80, PN 100	EN 1092-1 Type B2
E F	DN 80, PN 160	EN 1092-1 Type B2
E G	DN 80, PN 250	EN 1092-1 Type B2
F A	DN 100, PN 16	EN 1092-1 Type A
F B	DN 100, PN 25/40	EN 1092-1 Type A
F D	DN 100, PN 63	EN 1092-1 Type B2
F E	DN 100, PN 100	EN 1092-1 Type B2
F F	DN 100, PN 160	EN 1092-1 Type B2
F G	DN 100, PN 250	EN 1092-1 Type B2

<sup>①</sup> 7MF up to 600 lbs ANSI RF / PN 100 flanges

**PROCESS SEAL - MATERIAL**

**For 7MF**

0	Viton® GFLT seal - for universal use	-40 °C (-40 °F) / +150 °C (+300 °F)
2	Kalrez 4079 seal - for aggressive media	-40 °C (-40 °F) / +150 °C (+300 °F)
8	Aegis PF 128 seal - for NACE applications	-20 °C (-4 °F) / +150 °C (+300 °F)

**For 7MJ**

8	PEEK/Aegis PF 128 seal	-15 °C (-0 °F) / +315 °C (+600 °F)
---	------------------------	------------------------------------

Consult factory for alternative seal materials. For Ammonia/Chlorine applications, use the 7MD GWR probe. Viton® is a registered trademark of DuPont Performance Elastomers.

**INSERTION LENGTH – Specify insertion length per cm (0.39") increments**

0 6 0	minimum 60 cm (24") insertion length
6 1 0	maximum 610 cm (240") insertion length



**complete order code for ECLIPSE 705 - bare or PFA insulated GWR probe**

**DIMENSIONS in mm (inches)**

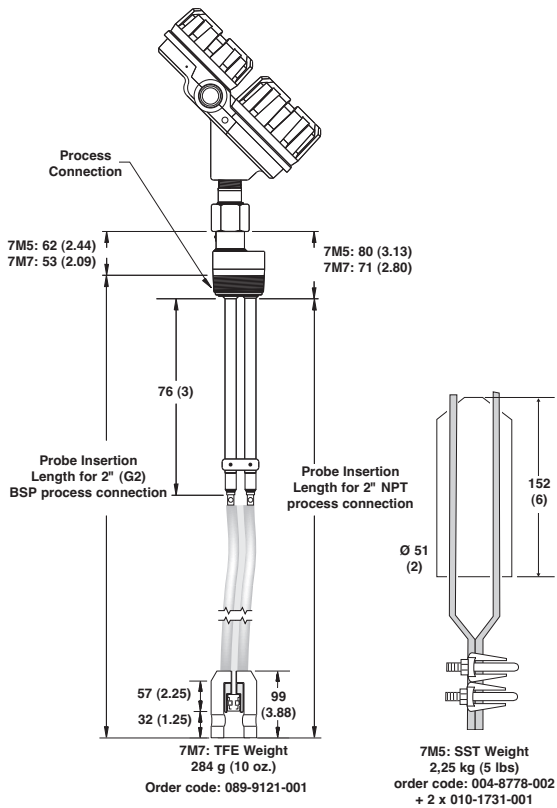

**7M5/7M7**  
with threaded connection  
max. 22 m (75')

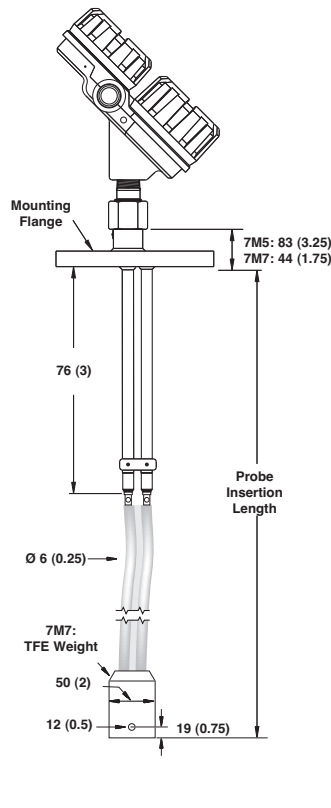

**7M5/7M7**  
with flanged connection  
max. 22 m (75')

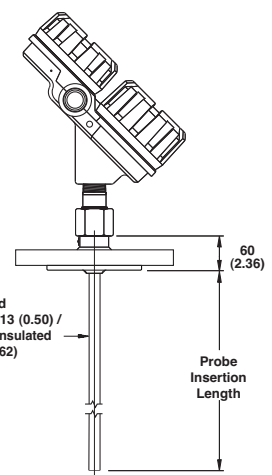

**7MF-F**  
with PFA faced-flanged  
connection  
max. 6,1 m (240")

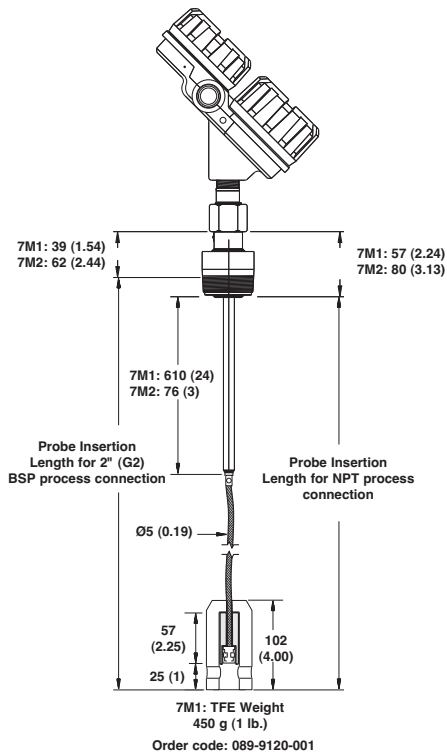

**7M1/7M2** with threaded connection  
max. 22 m (75')

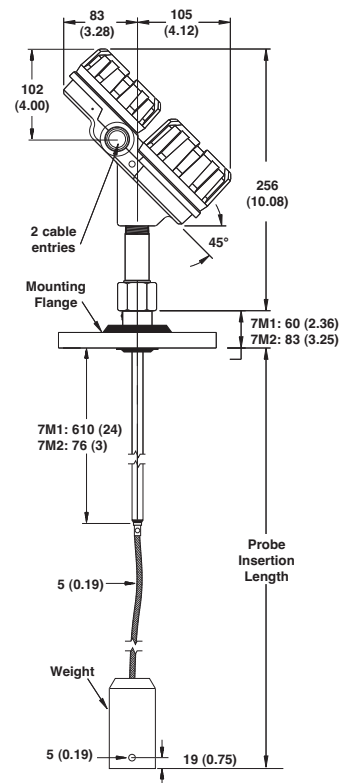
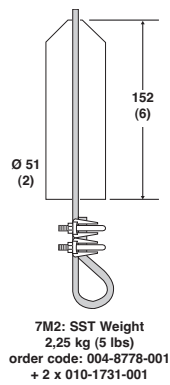

**7M1/7M2** with flanged connection  
max. 22 m (75')

**MOUNTING**

Consult mounting considerations on page 15

**2. Order code for ECLIPSE 705 - PFA insulated / PFA faced flange GWR probe - for aggressive liquids**

**BASIC MODEL NUMBER**

7	M	F	-	F	Single rod PFA insulated 316/316L (1.4401/1.4404) GWR probe	(dielectric range: $\geq 1,9/10$ ) <sup>①</sup>
---	---	---	---	---	---	---

<sup>①</sup> For dielectric range  $\geq 1,9$  and  $< 10$ , probe must be mounted within 50 - 150 mm (2" - 6") distance from the tank wall or in a cage or bridle. See mounting considerations on page 5

**PROCESS CONNECTION - SIZE/TYPE**

**ANSI flanged**

4	3	2"	150 lbs.	ANSI RF flange
4	4	2"	300 lbs.	ANSI RF flange
4	5	2"	600 lbs.	ANSI RF flange
5	3	3"	150 lbs.	ANSI RF flange
5	4	3"	300 lbs.	ANSI RF flange
5	5	3"	600 lbs.	ANSI RF flange
6	3	4"	150 lbs.	ANSI RF flange
6	4	4"	300 lbs.	ANSI RF flange
6	5	4"	600 lbs.	ANSI RF flange

**EN/DIN flanged**

D	A	DN 50, PN 16	EN 1092-1 Type A
D	B	DN 50, PN 25/40	EN 1092-1 Type A
D	D	DN 50, PN 63	EN 1092-1 Type B2
D	E	DN 50, PN 100	EN 1092-1 Type B2
E	A	DN 80, PN 16	EN 1092-1 Type A
E	B	DN 80, PN 25/40	EN 1092-1 Type A
E	D	DN 80, PN 63	EN 1092-1 Type B2
E	E	DN 80, PN 100	EN 1092-1 Type B2
F	A	DN 100, PN 16	EN 1092-1 Type A
F	B	DN 100, PN 25/40	EN 1092-1 Type A
F	D	DN 100, PN 63	EN 1092-1 Type B2
F	E	DN 100, PN 100	EN 1092-1 Type B2

**INSERTION LENGTH – Specify insertion length per cm (0.39") increments**

0	6	0	minimum 60 cm (24") insertion length
6	1	0	maximum 610 cm (240") insertion length

7	M	F	-	F		N		
---	---	---	---	---	--	---	--	--

**ECLIPSE 705 - PFA insulated / PFA faced flange GWR probe**

**2. Order code for ECLIPSE 705 - flexible cable GWR probe for liquids or solids**

**BASIC MODEL NUMBER<sup>①</sup>**

7	M	1	-	A	Single cable GWR probe in 316 stainless steel (1.4401) – for liquid level
7	M	7	-	A	Twin cable GWR probe in FEP coated 316 SST (1.4401) – for liquid level/interface
7	M	2	-	A	Single cable GWR probe in 316 stainless steel (1.4401) – for solids <sup>②</sup>
7	M	5	-	A	Twin cable GWR probe in TFE coated 316 SST (1.4401) – for solids <sup>②</sup>

<sup>①</sup> For dielectric ranges, consult page 23.

<sup>②</sup> use only Viton<sup>®</sup> process seal

**PROCESS CONNECTION - SIZE/TYPE**

**Threaded**

4	1	2" NPT thread
4	2	2" BSP (G2) thread

**ANSI flanged**

4	3	2"	150 lbs.	ANSI RF flange <sup>①</sup>
4	4	2"	300 lbs.	ANSI RF flange <sup>①</sup>
4	5	2"	600 lbs.	ANSI RF flange <sup>①</sup>
5	3	3"	150 lbs.	ANSI RF flange
5	4	3"	300 lbs.	ANSI RF flange
5	5	3"	600 lbs.	ANSI RF flange
6	3	4"	150 lbs.	ANSI RF flange
6	4	4"	300 lbs.	ANSI RF flange
6	5	4"	600 lbs.	ANSI RF flange

**EN/DIN flanged**

D	A	DN 50, PN 16	EN 1092-1 Type A <sup>①</sup>
D	B	DN 50, PN 25/40	EN 1092-1 Type A <sup>①</sup>
D	D	DN 50, PN 63	EN 1092-1 Type B2 <sup>①</sup>
D	E	DN 50, PN 100	EN 1092-1 Type B2 <sup>①</sup>
E	A	DN 80, PN 16	EN 1092-1 Type A
E	B	DN 80, PN 25/40	EN 1092-1 Type A
E	D	DN 80, PN 63	EN 1092-1 Type B2
E	E	DN 80, PN 100	EN 1092-1 Type B2
F	A	DN 100, PN 16	EN 1092-1 Type A
F	B	DN 100, PN 25/40	EN 1092-1 Type A
F	D	DN 100, PN 63	EN 1092-1 Type B2
F	E	DN 100, PN 100	EN 1092-1 Type B2

<sup>①</sup> Not available with 7M7/7M5 GWR probes

**PROCESS SEAL - MATERIAL**

0	Viton <sup>®</sup> GFLT seal - for universal use	-40 °C (-40 °F) / +200 °C (+400 °F)
2	Kalrez 4079 seal - for aggressive media	-40 °C (-40 °F) / +200 °C (+400 °F)

Consult factory for alternative seal materials. For ammonia/chloride applications, use the 7MD GWR probe. Viton<sup>®</sup> is a registered trademark of DuPont Performance Elastomers.

**INSERTION LENGTH: – Specify insertion length per 1 m (3,28') increments**  
Probes can be cut to exact length in the field

0	0	1	minimum 1 m (3,28') insertion length - 7M1
0	0	2	minimum 2 m (6,56') insertion length - 7M2/7M7/7M5
0	1	2	maximum 12 m (40') insertion length - 7M7 for liquids interface
0	2	2	maximum 22 m (75') insertion length - all except 7M7 for liquids interface

7	M		-	A			
---	---	--	---	---	--	--	--

**complete order code for ECLIPSE 705 - flexible cable GWR probe**

# TRANSMITTER SPECIFICATIONS

## FUNCTIONAL/PHYSICAL

Description		Specification
Power (at terminals)		General Purpose / ATEX Intrinsically Safe: 11 to 28,6 V DC ATEX Explosion Proof (with Intrinsically Safe probe) 11 to 36 V DC Foundation Fieldbus™ and Profibus PA™ (FISCO ATEX Exi): 9 to 17,5 V DC Foundation Fieldbus™ and Profibus PA™ (FNICO & Exd): 9 to 32 V DC
Signal Output		4-20 mA with HART®, 3,8 mA to 20,5 mA useable (meets NAMUR NE 43), Foundation Fieldbus™ H1 (ITK Ver. 4) or Profibus PA™ H1
Span	Rigid probes	150 to 6100 mm (6 to 240") except 7MS: max 4500 mm (177")
	Flexible probes	15 cm to 2285 cm (6 to 75')
Resolution		Analog: 0,01 mA Display: 0,1 cm (inch)
Loop Resistance (see tables at page 12)		630 Ω @ 20,5 mA - 24 V DC
Damping		Adjustable 0-10 s
Diagnostic Alarm		Adjustable 3,6 mA, 22 mA, HOLD
User Interface		HART® communicator, AMS® or PACTware®, Foundation Fieldbus™, Profibus PA and/or 3-button keypad
Display		2-line x 8-character LCD
Menu Language		English/Spanish/French/German (Foundation Fieldbus™, Profibus PA: English)
Housing Material		IP 66/Aluminium A356T6 (< 0.20 % copper) or stainless steel
Approvals		ATEX II 3 (1) G EEx nA [ia] IIC T6, non sparking (probe can be used in flammable liquids) ATEX II 3 (1) G EEx nA [nL][ia] IIC T6, FNICO – non incendive (probe can be used in flammable liquids) ATEX II 1 G EEx ia IIC T4, intrinsically safe ATEX II 1 G EEx ia IIC T4, FISCO – intrinsically safe ATEX II 1 / 2 G D EEx d[ia] IIC T6, explosion proof <sup>①</sup> FM and CSA, Non incendive, intrinsically safe (FISCO) and explosion proof  Foundation Fieldbus™ and Profibus PA units are FNICO (non sparking), FISCO (intrinsically safe) and ATEX – FM/CSA explosion proof approved  EN 12952-11 and EN 12953-9 CE approved for steam drums as primary level safety device TÜV – WHG § 19, VLAREM II 5.17-7 LRS – Lloyds Register of Shipping (marine applications) GOST-K/GGTN-K – RosTECH/FSTS – Russian Authorisation Standards
SIL <sup>②</sup> (Safety Integrity Level)	Standard electronics	Functional safety to SIL 1 as 1oo1 / SIL 2 as 1oo2 in accordance to 61508 – SFF of 85,4 % – full FMEDA reports and declaration sheets available at request
	Enhanced electronics	Functional safety to SIL 2 as 1oo1 in accordance to 61508 – SFF of 91 % – full FMEDA reports and declaration sheets available at request
Electrical Data		U <sub>i</sub> = 28,4 V, I <sub>i</sub> = 94 mA, P <sub>i</sub> = 0,67 W U <sub>i</sub> = 0,56 V, I <sub>i</sub> = 380 mA, P <sub>i</sub> = 5,32 W (Foundation Fieldbus™ / Profibus PA™)
Equivalent Data		C <sub>i</sub> = 2,2 nF, L <sub>i</sub> = 3 μH C <sub>i</sub> = 0,24 nF, L <sub>i</sub> = 3 μH (Foundation Fieldbus™ / Profibus PA™)
Shock/Vibration Class		ANSI/ISA-571.03 SA1 (Shock), ANSI/ISA-571.03 VC2 (Vibration)
Net and Gross Weight	Cast aluminium	2,70 kg net; 3,20 kg gross – amplifier only
	Stainless steel	5,70 kg net; 6,20 kg gross – amplifier only
Overall Dimensions		H 214 mm (8.43") x W 111 mm (4.38") x D 188 mm
Foundation Fieldbus™ specifications	ITK Version	4.61
	H1 Device Class	Link Master (LAS) – selectable ON/OFF
	H1 Profile Class	31PS, 32L
	Function Blocks	1 x RB (s), 4 x AI (s) and 1 x TB (c)
	Quiescent current draw	15 mA
	Execution time	15 ms
	CFF files	Downloads available from Host system supplier or <a href="http://www.fieldbus.org">www.fieldbus.org</a>
Profibus PA specifications	Device revision	0x01
	Digital communication protocols	Version 3.0 MBP (31.25 kbits/sec)
	Function Blocks	4 x AI blocks
	Quiescent current draw	15 mA
	Execution time	15 ms
GSD files		Downloads available from <a href="http://www.profibus.com">www.profibus.com</a> or <a href="http://Magnetrol.com">Magnetrol.com</a>

① ATEX, explosion proof units use EEx d bushing material STYCAST 2057 FR.

② Not applicable for Foundation Fieldbus™ and Profibus PA™ units.

## PERFORMANCE

Description		Specification
Reference Conditions with a 1,8 m (72") coaxial type GWR probe		Reflection from liquid, with dielectric in center of selected range, at +20 °C (70 °F) with CFD threshold <sup>①</sup>
Linearity <sup>②</sup>	Coaxial/twin lead probes	< 0,1 % of probe length or 2,5 mm (0.1"), whichever is greater
	Single lead probes	< 0,3 % of probe length or 8 mm (0.3"), whichever is greater
Accuracy <sup>②</sup>	Coaxial/twin lead probes	< 0,1 % of probe length or 2,5 mm (0.1"), whichever is greater
	Single lead probes	± 0,5 % of probe length or 13 mm (0.5"), whichever is greater
	7MT/7ML interface	± 25 mm (1")
Resolution		± 2,5 mm (0.1")
Repeatability		< 2,5 mm (0.1")
Hysteresis		< 2,5 mm (0.1")
Response Time		< 1 second
Warm-up Time		< 5 seconds
Ambient Temp.		-40 °C to +80 °C (-40 °F to +175 °F) – blind transmitter -20 °C to +70 °C (-5 °F to +160 °F) – with digital display -40 °C to +70 °C (-40 °F to +160 °F) – for EEx ia and EEx d[ia] with blind transmitter -20 °C to +70 °C (-5 °F to +160 °F) – for EEx ia and EEx d[ia] with digital display
Process Dielectric Effect		< 7,5 mm (0.3") within selected range
Operating Temp. Effect		Approx. +0,02 % of probe length/°C for probes ≥ 2,5 m (8") <sup>③</sup>
Humidity		0-99 %, non-condensing
Electromagnetic Compatibility		Meets CE requirements (EN-61326: 1997 + A1 + A2) and NAMUR NE 21 (Single and Twin-Rod probe must be used in metallic vessel or stillwell)

## PROBE SPECIFICATIONS

Description		7MR/7MM: overfill protection coaxial probe <sup>④</sup>
Materials	Probe	316/316L (1.4401/1.4404) with TFE spacers Hastelloy C <sup>®</sup> (2.4819) or Monel <sup>®</sup> (2.4360) with TFE spacers
	Process seal	TFE with Viton <sup>®</sup> GFLT, Aegis <sup>®</sup> PF 128 or Kalrez 4079 (Consult factory for alternatives)
Probe diameter	Small coax	Inside rod 8 mm (0.31) – outer tube 22,5 mm (0.87")
	Large coax <sup>⑤</sup>	Stainless steel: Inside rod 16 mm (0.63) – outer tube 45 mm (1,75") Hastelloy C and Monel: Inside rod 16 mm (0.63) – outer tube 49 mm (1.29")
Process Connection		Threaded: 3/4" NPT or 1" BSP (G1) – except for large Ø probe Flanged: Various ANSI, DIN or torque tube mating flanges
Probe length (selectable per 1 cm)		From 45 cm to 610 cm (18 to 240"), selectable per 10 mm
Transition Zone <sup>①</sup>	Top	0 mm (0")
	Bottom	Er: 1,4 = 150 mm (6")/Er: 80 = 25 mm (1")
Max. Process Temp. <sup>③</sup>	Max	+200 °C @ 18 bar (+400 °F @ 270 psi)
	Min	-40 °C @ 50 bar (-40 °F @ 750 psi)
Max. Process Pressure <sup>③</sup>		70 bar @ +20 °C (1000 psi @ +70 °F)
Dielectric Range – Max. Viscosity		1,4 to 100 – 500 cP / 2000 cP (enlarged) <sup>⑤</sup>

Description		7MD/7ML: high pressure / high temperature GWR probe <sup>④</sup>	7MS: saturated steam GWR probe
Materials	Probe	316/316L (1.4401/1.4404), Hastelloy C <sup>®</sup> (2.4819) or Monel <sup>®</sup> (2.4360)	
	Process seal	Borosilicate / Inconel <sup>®</sup> X-750	High Temp PEEK with Aegis PF 128
	Spacers	Alumina (7MD-A, B and C) – TFE (7MD-W) – High Temp PEEK (7MD-V, N, P and R)	High Temp PEEK
Probe diameter	Small coax	Inside rod 8 mm (0.31) – outer tube 22,5 mm (0,87")	
	Large coax <sup>⑤</sup>	Stainless steel: Inside rod 16 mm (0.63) – outer tube 45 mm (1,75") Hastelloy C and Monel: Inside rod 16 mm (0.63) – outer tube 49 mm (1.93")	
Process Connection		Threaded: 3/4" NPT or 1" BSP (G1) – except for large Ø probe Flanged: Various ANSI, DIN or "proprietary" mating flanges	
Probe length (selectable per 1 cm)		From 60 cm to 610 cm (24 to 240")	From 60 cm to 450 cm (24 to 177")
Transition Zone <sup>①</sup>	Top	0 mm (0")	
	Bottom	Er: 1,4 = 150 mm (6") / Er: 80 = 25 mm (1")	Er ≥ 10 = 25 mm (1")
MaxProcess Temp. <sup>③</sup>	Max	+430 °C @ 135 bar (+800 °F @ 2000 psi) +345 °C (+650 °F) for 7Mx-V, N, P and R +200 °C (+400 °F) for 7Mx-W	+345 °C @ 155 bar (+650 °F @ 2250 psi)
	Min	-196 °C @ 430 bar (-320 °F @ 6250 psi)	-15 °C @ 205 bar (0 °F @ 3000 psi)
Max. Process Pressure <sup>③</sup>		430 bar @ +20 °C (6250 psi @ +70 °F)	155 bar @ +345 °C (2250 psi @ +650 °F)
Max. Viscosity		500 cP (standard) / 2000 cP (enlarged) <sup>⑤</sup>	
Dielectric Range		Er ≥ 1,4-100: 7Mx-W Er ≥ 1,7-100: 7Mx-V, N, P and R Er ≥ 2,0-100: 7Mx-A, B and C	10 to 100
Vacuum service		Full vacuum (Helium leak < 10 <sup>-8</sup> cc/s @ 1 atmosphere vacuum)	Negative pressure but not up to full vacuum

<sup>①</sup> May degrade for 7MD/7ML probe or with fixed threshold.

<sup>②</sup> Top 600 mm (24") of twin rod probe: 30 mm (1.18").  
Top 1220 mm (48") of single rod: application dependant.

<sup>③</sup> Accuracy may degrade slightly < 2,5 m (8')

<sup>④</sup> Consult factory for insertion length < 60 cm (24")

<sup>⑤</sup> Consult bulletin 57-102

Description		7MT/7MN: interface GWR probe <sup>④</sup>	7MB: standard twin rod GWR probe
Materials	Probe	316/316L (1.4401/1.4404) Hastelloy C <sup>®</sup> (2.4819) or Monel <sup>®</sup> (2.4360)	
	Process seal	TFE with Viton <sup>®</sup> GFLT or Kalrez 4079 (Consult factory for alternatives)	
	Spacers	Teflon	
Probe diameter	Small coax	Inside rod 8 mm (0.31) – outer tube 22,5 mm (0,87")	Two 13 mm (0.5") Ø rods – 22 mm (0.875") $\varnothing$ to $\varnothing$
	Large coax <sup>⑤</sup>	<b>Stainless steel:</b> Inside rod 16 mm (0.63) – outer tube 45 mm (1.75") <b>Hastelloy C and Monel:</b> Inside rod 16 mm (0.63) – outer tube 49 mm (1.29")	
Mounting		In-tank mounting / external cage mounting – overflow safe	In-tank mounting only. Twin rod probe must be used in metallic vessel or stillwell > 25 mm (1") from any surface or obstruction
Process Connection		Threaded: 3/4" NPT or 1" BSP (G1) Flanged: Various ANSI, DIN or "proprietary" mating flanges	Threaded: 2" NPT or 2" BSP (G2) Flanged: Various ANSI, DIN or "proprietary" mating flanges
Probe length (selectable per 1 cm)		From 60 cm to 610 cm (24 to 240"), selectable per 10 mm	
Transition Zone <sup>①</sup>	Top	0 mm (0")	$\epsilon_r \geq 1,9 = 150 \text{ mm (6")}$
	Bottom	$\epsilon_r: 1,4 = 150 \text{ mm (6")}/\epsilon_r: 80 = 50 \text{ mm (2")}$	$\epsilon_r: 1,9 = 150 \text{ mm (6")}/\epsilon_r: 80 = 25 \text{ mm (1")}$
Process Temp. <sup>③</sup>	Max	+200 °C @ 18 bar (+400 °F @ 270 psi)	+150 °C @ 20 bar (+300 °F @ 300 psi) / +200 °C (+400 °F) with max ambient temp. of +30 °C (+86 °F)
	Min	-40 °C @ 50 bar (-40 °F @ 750 psi)	
Max. Process Pressure <sup>③</sup>		70 bar @ +20 °C (1000 psi @ +70 °F)	50 bar @ +20 °C (750 psi @ +70 °F)
Dielectric Range – Max. Viscosity		Upper liquid: $\geq 1,4$ and $\leq 5$ Lower liquid: $\geq 15$	1,9 to 100 – 1500 cP
Vacuum service		Negative pressure but not up to full vacuum	
Media coating		In case of media coating, select 7MN probe.	Film: 3% error of coated length, bridging not recommended <sup>②</sup>

Description		7MF: standard single rod	7MJ: HTHP single rod
Materials	Probe	316/316L (1.4401/1.4404), Monel <sup>®</sup> (2.4360), Hastelloy C <sup>®</sup> (2.4819) or PFA insulated 316/316L (1.4401/1.4404)	
	Process seal	TFE with Viton <sup>®</sup> GFLT or Kalrez 4079 (Consult factory for alternatives)	
Probe diameter		Bare: 13 mm (0.50") - PFA coated: 16 mm (0.625")	Bare: 13 mm (0.50")
Mounting		See mounting considerations on page 15	
Process Connection		Threaded: 2" NPT or 2" BSP (G2) – Flanged: Various ANSI or EN/DIN	
Probe length		From 600 mm to 6100 mm (24" to 240") (selectable per 1 cm)	
Blocking distance (top)		120 mm up to 910 mm (4.8" up to 36") - depending probe length (adjustable)	
Transition Zone <sup>①</sup> (bottom)		$\epsilon_r \geq 10: 25 \text{ mm (1")}$	
Process Temp.	Max	+150 °C @ 27 bar (+300 °F @ 400 psi) ambient	+315 °C @ 110 bar (+600 °F @ 1600 psi)
	Min	-40 °C @ 50 bar (-40 °F @ 750 psi) – 13,7 bar (200 psi) for 7MF-F	
Max Process Pressure		70 bar @ +20 °C (1000 psi @ +70 °F)	207 bar @ +20 °C (3000 psi @ +70 °F)
Max Viscosity		10.000 cP – consult factory in case of agitation/turbulence	
Dielectric Range		$\epsilon_r$ 10-100 (depending installation conditions, down to $\epsilon_r \geq 1,9$ ) – liquids	
Mechanical load		Not applicable	
Pulldown force		Not applicable	
Media coating		Max error of 10 % of coated length. % Error is related to dielectric of medium, thickness of coating and coated probe length above level.	

① Transition Zone (zone with reduced accuracy) is dielectric dependent;  $\epsilon_r$  = dielectric permittivity. It is recommended to set 4-20 mA signal outside transition zones.

② Bridging is defined as continuous accumulation of material between the probe elements.

③ See tables at page 23.

④ Consult factory for insertion length < 60 cm (24")

⑤ Consult bulletin 57-102

Description		7M1 (liquids) / 7M2 (solids): single flexible	7M5 (solids) / 7M7 (liquids): twin flexible
Materials	Probe	316 SST (1.4401)	7M7: FEP coated 316 SST (1.4401) 7M5: TFE coated 316 SST (1.4401)
	Process seal	TFE with Viton® GFLT, EPDM or Kalrez 4079 (Consult factory for alternatives)	
Probe diameter		7M1: 5 mm (0.19") 7M2: 6 mm (0.25")	6 mm (0.25")
Mounting		See mounting considerations on page 15	< 25 mm (1") from any surface or construction
Process Connection		Threaded: 2" NPT or 2" BSP (G2) – Flanged: Various ANSI, EN/DIN or sanitary	
Probe length		From 1 m (3') (7M1) - 2 m (6') (7M2, 7M5, 7M7) to max 22 m (75') (selectable per 1 m)	
Blocking distance (top)		120 mm up to 910 mm (4.8" up to 36") - depending probe length (adjustable)	300 mm to 500 mm (12" to 20") - level 450 mm to 500 mm (18" to 20") - interface
Transition Zone <sup>①</sup> (bottom)		305 mm (12")	
Max Process Temp.		+150 °C @ 27 bar (300 °F @ 400 psi) – 7M2/7M5: Ambient	
Max Process Pressure		7M1/7M7: 70 bar @ +20 °C (1000 psi @ +70 °F) 7M2/7M5: 3.4 bar (50 psi)	
Max Viscosity		10.000 cP – consult factory in case of agitation/turbulence	1500 cP
Dielectric Range	Liquids	$\epsilon_r$ : 1,9 - 100 <sup>②</sup> $\epsilon_r$ : 10-100	Level: $\epsilon_r$ 1,9-100 Interface: upper liquid: $\epsilon_r \geq 1,9$ and $\leq 3,0$ lower liquid: $\epsilon_r \geq 15$
	Solids	$\epsilon_r$ : 1,4 - 100	$\epsilon_r$ : 1,9 - 100
Mechanical load		9 kg (20 lbs) – 7M1	
Pulldown force		1360 kg (3000 lbs) – 7M2	1360 kg (3000 lbs) – 7M5
Media coating		Max error of 10 % of coated length. % Error is related to dielectric of medium, thickness of coating and coated probe length above level.	Film: 3 % max error of coated length with conductive media – Bridging not recommended

<sup>①</sup> Transition Zone (zone with reduced accuracy) is dielectric dependent;  $\epsilon_r$  = dielectric permittivity. It is recommended to set 4-20 mA signal outside the transition zone / blocking distance.

<sup>②</sup> For dielectric range  $\geq 1,9$  and  $< 10$ , probe must be mounted within 50 - 150 mm (2" - 6") distance from the tank wall or in a cage or bridle. See mounting considerations on page 5

Viton® is a registered trademark of DuPont Performance Elastomers.

# TEMPERATURE-PRESSURE RATING FOR ECLIPSE PROBE SEALS

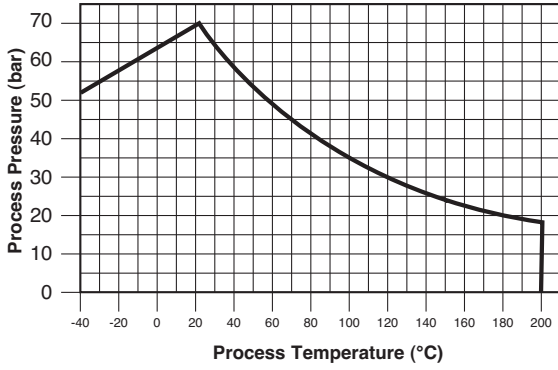

7MR/7MT/7MM/7MN GWR probes

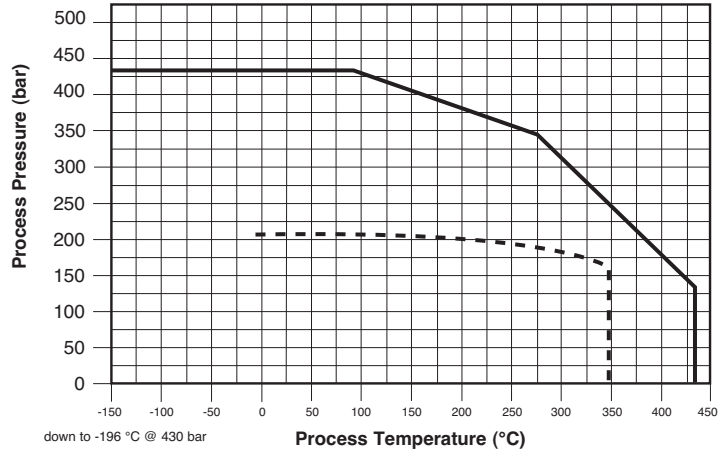

7MD/7ML GWR probe

7MS/7MJ GWR probes (7MJ max +315 °C)

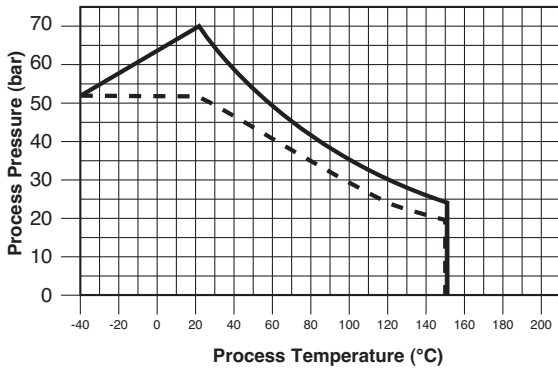

7M1/7M7/7MF GWR probes

7MB GWR probes

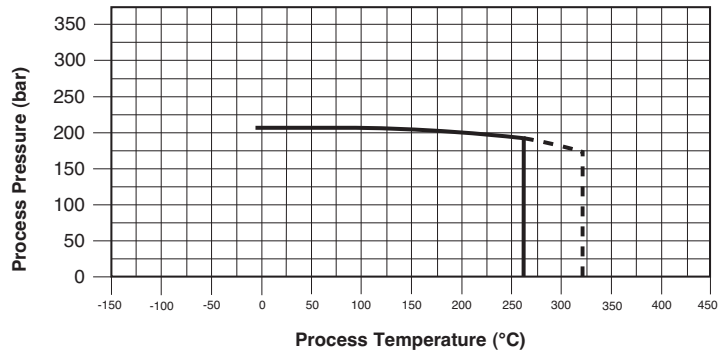

7EK: top/bottom GWR probe: max +260 °C for conductive and non conductive liquids

7EK: top/bottom GWR probe: max +320 °C for conductive liquids only



## QUALITY ASSURANCE - ISO 9001:2000

THE QUALITY ASSURANCE SYSTEM IN PLACE AT MAGNETROL GUARANTEES THE HIGHEST LEVEL OF QUALITY DURING THE DESIGN, THE CONSTRUCTION AND THE SERVICE OF CONTROLS. OUR QUALITY ASSURANCE SYSTEM IS APPROVED AND CERTIFIED TO ISO 9001:2000 AND OUR TOTAL COMPANY IS COMMITTED TO PROVIDING FULL CUSTOMER SATISFACTION BOTH IN QUALITY PRODUCTS AND QUALITY SERVICE.

## PRODUCT WARRANTY

ALL MAGNETROL ELECTRONIC AND ULTRASONIC LEVEL CONTROLS ARE WARRANTED FREE OF DEFECTS IN MATERIALS AND WORKMANSHIP FOR ONE FULL YEAR FROM THE DATE OF ORIGINAL FACTORY SHIPMENT. IF RETURNED WITHIN THE WARRANTY PERIOD; AND, UPON FACTORY INSPECTION OF THE CONTROL, THE CAUSE OF THE CLAIM IS DETERMINED TO BE COVERED UNDER THE WARRANTY; THEN, MAGNETROL INTERNATIONAL WILL REPAIR OR REPLACE THE CONTROL AT NO COST TO THE PURCHASER (OR OWNER) OTHER THAN TRANSPORTATION.

MAGNETROL SHALL NOT BE LIABLE FOR MISAPPLICATION, LABOR CLAIMS, DIRECT OR CONSEQUENTIAL DAMAGE OR EXPENSE ARISING FROM THE INSTALLATION OR USE OF THE EQUIPMENT. THERE ARE NO OTHER WARRANTIES EXPRESSED OR IMPLIED, EXCEPT, SPECIAL WRITTEN WARRANTIES COVERING SOME MAGNETROL PRODUCTS.



BULLETIN N°:  
EFFECTIVE:  
SUPERSEDES:

BE 57-101.17  
MARCH 2009  
April 2008

UNDER RESERVE OF MODIFICATIONS

BENELUX FRANCE	Heikensstraat 6, 9240 Zele, België -Belgique Tél. +32 (0)52.45.11.11 • Fax. +32 (0)52.45.09.93 • E-Mail: info@magnetrol.eu
DEUTSCHLAND	Alte Ziegelei 2-4, D-51491 Overath Tel. +49 (0)2204 / 9536-0 • Fax. +49 (0)2204 / 9536-53 • E-Mail: vertrieb@magnetrol.de
INDIA	C-20 Community Centre, Janakpuri, New Delhi - 110 0058 Tel. +91 (11) 41661840 • Fax +91 (11) 41661843 • E-Mail: info@magnetrolindia.com
ITALIA	Via Arese 12, I-20159 Milano Tel. +39 02 607.22.98 (R.A.) • Fax. +39 02 668.66.52 • E-Mail: mit.gen@magnetrol.it
U.A.E.	DAFZA Office 5EA 722 • PO Box 293671 • Dubai Tel. +971-4-6091735 • Fax +971-4-6091736 • E-Mail: info@magnetrol.ae
UNITED KINGDOM	Unit 1 Regent Business Centre, Jubilee Road Burgess Hill West Sussex RH 15 9TL Tel. +44 (0)1444 871313 • Fax +44 (0)1444 871317 • E-Mail: sales@magnetrol.co.uk

www.magnetrol.com

OUR NEAREST REPRESENTATIVE